



**HOFFMAN**

# SERIES 1001A

## TYPE Y OR Z

### PRESSURIZATION / PURGING KITS INSTALLATION & OPERATION MANUAL

**CLASS I APPLICATIONS**  
2 Cubic Feet Maximum  
**CLASS II APPLICATIONS**  
10 Cubic Feet Maximum



Face Plate w/ Universal Flange Attached



Universal Flange



Accessories Supplied with Each Kit



Manufactured by:



1600 Enterprise Parkway • Twinsburg, Ohio 44087

© 2010 Pepperl+Fuchs® Inc., Twinsburg, Ohio  
511821, Dwg No. 129-0200B, Printed in U.S.A

nVent **HOFFMAN**

2100 Hoffman Way  
Anoka, Minnesota 55303  
PH 763 422 2211  
nVent.com/HOFFMAN  
Hoffman P/N #87571946

## Table of Contents

<b>Page 2</b>	<b>System Purpose and Description</b> Purpose, System Description, Important Notes	<b>Page 13</b>	<b>Pneumatic Tubing Requirements</b> Protective Gas Supply Requirements, Pneumatic Connection Requirements
<b>Page 3</b>	<b>Identifying Your System</b> Defines specific features of the system	<b>Page 14</b>	<b>Tubing Installation</b> LH, RH, TM, BM, WM, FM & PM Tubing Configurations
<b>Page 4</b>	<b>General Information</b> System & Material Specifications, System Accessories, Spare Parts, Tools & Test Equipment	<b>Page 15</b>	<b>Tubing Connection Diagrams</b> LH, RH, TM, BM, WM, FM, & PM Configuration Connection Points, Pneumatic Diagram
<b>Page 5</b>	<b>Enclosure and Device Design</b> Design Requirements, Adjacent Enclosures, Device Ventilation, Temperature Limitations	<b>Page 16</b>	<b>Conduit Installation</b> Electrical & WPS Style Conduit and Connection Parts
<b>Page 6</b>	<b>Installation Overview</b> Installation Diagram	<b>Page 17</b>	<b>Set-Up Procedure</b> Class I & Class II Set-up
<b>Page 7</b>	<b>Getting Started</b> Establishing Connection Sizes, Determining Enclosure Inlet & Outlet Connection Locations	<b>Page 18</b>	<b>Operating Sequence</b> Class I & Class II Operation
<b>Page 8</b>	<b>System Mounting</b> LH, RH, TM, BM & WM Configurations, FM & PM Configurations	<b>Page 19</b>	<b>Troubleshooting Procedures</b> Troubleshooting Chart
<b>Page 9</b>	<b>Special Mounting Information</b> ECK, ILFK Connection Diagram, Typical Panel Mount Diagram	<b>Page 20</b>	<b>Warranty and Liability Statement</b> Warranty Notes, General Terms, Limitations
<b>Page 10</b>	<b>Mounting Plate Dimensions</b> Mounting Plate Dimension Diagrams	<b>Page 21</b>	<b>System Maintenance</b> Regular Maintenance, Long-term Maintenance, Maintenance Schedule
<b>Page 11</b>	<b>Mounting Plate Dimensions (cont.)</b> Mounting Plate Dimension Diagrams	<b>Page 22</b>	<b>Customer Notes</b>
<b>Page 12</b>	<b>Hardware Mounting</b> Optional Enclosure Protection Vent, Warning Nameplates	<b>Page 24</b>	<b>Systems Identification &amp; Application Information</b>

### Purpose

Pepperl+Fuchs' Bebc0 EPS System allows the use of general-purpose or nonrated electrical or electronic devices, with exception to devices which produce excessive heat, utilize combustible gas, or expose arcing contacts to the hazardous atmosphere, in NEMA (National Electrical Manufacturers Association) 4 or 12 enclosures in the place of explosion proof NEMA 7 enclosures. Other purposes include heat, moisture and dust contamination prevention.

### Description

Model 1001A is an enclosure pressurization or purging system that operates on a supply of compressed instrument air or inert gas. It regulates and monitors pressure within sealed (protected) enclosures, to prevent combustible dust accumulation or remove and prevent flammable gas or vapor accumulations. In Class II areas, the system maintains a "safe" (1.0") pressure. In Class I areas, the system accomplishes four air exchanges and maintains a "safe" (0.25") pressure. These processes reduce the hazardous (classified) area rating within the enclosure(s), in accordance with the NEC - NFPA 70, Article 500, NFPA 496 and ISA 12.4

### Important Notes

One (1) permanent file copy and one (1) operations copy of this Manual must be studied and retained by the operator of this System. User's Agents are responsible for transferring this Manual to the user, prior to start-up.

The contents of this manual have been arranged to allow the use of this product as a stand-alone device on equipment and enclosures supplied by the user or its agents. The Manual's parameters encompass a combination of both National Fire Protection Association (NFPA) requirements and Pepperl+Fuchs, Inc. requirements. Pepperl+Fuchs therefore acknowledges the use of NFPA 496 as a guideline, that we have enhanced certain NFPA requirements and that additional information has been compiled to complete this document. The Manual is intended as a complete guide and must be considered, unless specifically stated otherwise, that all directives contained herein are requirements for safe, practical and efficient use of this product.

This System is not intended for use to protect enclosures or devices which contain ignitable concentrations of gases or vapors. This exclusion generally applies to process or product analyzing systems equipment.

**All specifications are subject to change without notice.**

# Identifying Your System

This Enclosure Protection System is offered in various styles. For proper installation and operation, examine the System Model Number Nameplate to identify the System Style, Area Classification, and Type, as noted below.

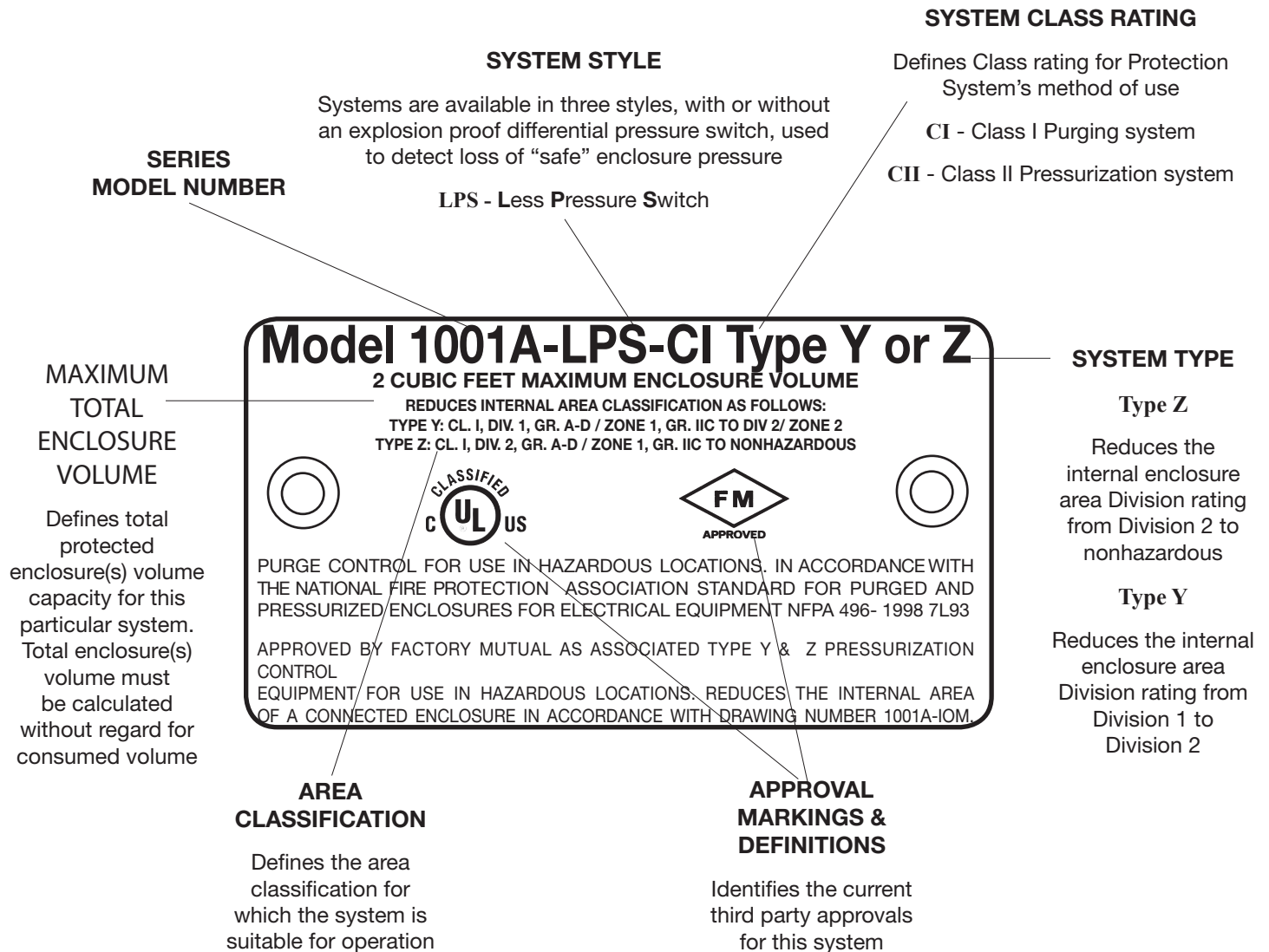

To assist you through the installation and operation of your pressurization / purge system, Pepperl+Fuchs, Inc. has provided the following information boxes throughout this manual. This information is intended to clarify certain differences between the model styles and configurations and to warn the user / installer of potential dangers of electrical shock or enclosure over pressurization.

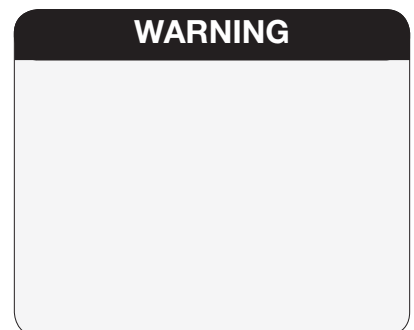
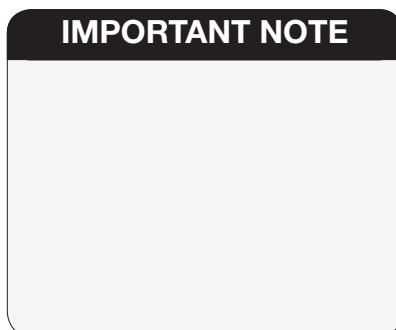
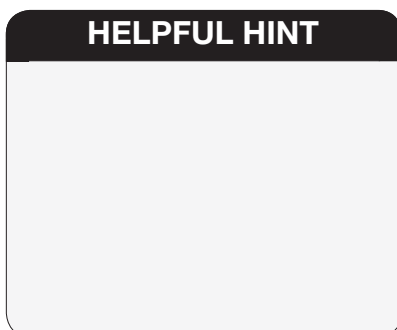

# General Information

## System Specifications

System Dimensions:	See Pages 10 & 11
Shipping Weight ( lbs.):	LPS - 5
Operating Temp. Range:	40° F - 120° F
Supply Pressure Range:	* 5 -120 PSI max.
Supply Requirements:	Clean Air or Inert Gas
Safe Press. (CI/CII):	0.25" / 1.0"
Safe Pressure Flowrate:	** 0.1-3.5 SCFH
System Supply Fitting:	1/4" Tube Fitting
Enclosure Supply Fitting:	1/4" Tube Fitting
Enclosure Reference Fitting:	1/4" Tube Fitting

- \* With Enclosure Protection Vent - 120 PSI maximum  
Without Enclosure Protection Vent - 5 PSI maximum

In order to comply with the NFPA 496 standard requiring protection against over pressurization of the protected enclosure, the installer must install one of the following items in addition to the enclosure protection system.

- Install a Enclosure Protection Vent on the protected enclosure.
- Install a tamper-proof regulator upstream of the enclosure protection system's system supply inlet to pre-regulate protective gas supply to 5 PSI max.

In addition, for small, tightly sealed enclosures, or to compensate for a fluctuating protective gas supply, it may be necessary to pre-regulate the protective gas supply to a constant 5 PSI regardless of whether an Enclosure Protection Vent is installed. This will reduce the amount of "drifting" that can normally occur when maintaining a "Safe" pressure inside a protected enclosure. The pre-regulation can be accomplished by installing the TR-10 or TR-10G Tamper-Proof Regulator accessories or equivalent.

## Material Specifications

Regulator Body:	Zinc w/ Enamel Finish, Brass
Regulator Handle:	Polycarbonate
Enclosure Pressure Gauge:	ABS Plastic
Tube Fittings:	316 SS Forged Body
Tubing:	316 SS 1/4" .035 Welded
System Nameplates:	Silkscreened Lexan® & SS
Fastener Hardware:	Zink Plated & Stainless Steel
Mounting Plate:	316 14 Ga #3 Brush SS
EXP Pressure Switch Body:	Anodized Cast Alum.
Enclosure Warning Nameplate:	Silkscreened SS

## Recommended Spare Parts

Qty	Description	Part # (supercedes)
1	Enclosure Pressure Indicator-CI	510023
1	Enclosure Pressure Indicator-CII	513235
1	Enclosure Pressure Control Regulator	513653
1	Installation & Operation Manual	129-0200
1	Enclosure Warning Nameplate-CI	513008
1	Enclosure Warning Nameplate-CII	513009

Please call and reference the above part number for current spare parts pricing. Immediate pricing is available to all confirmed customers.

## Installation Tools & Testing Equipment

1/2" chuck drill  
Complete set of drill bits  
1/2" conduit knockout punch or 0.875" hole saw  
Complete set of tubing, conduit bending, instrument fitting and electrical craftsman hand tools  
0 - 250 scfh flowmeter (connected upstream of the Protection System to determine air consumption and flow during set-up procedure)

## Model 1001A System Accessories

### Optional Enclosure Protection Vents

EPV-1-SA-00	Straight w/ Spark Arrestor
EPV-1-SA-90	Rt Angle w/ Spark Arrestor

### Additional Items

SMK-1, -4*	System Mounting Kit
ILFK-4*	1/4" In-line Filter Kit
SC-4*	1/4" x 1/4" straight Connector
EPSK-1	Class I, Group C - D Pressure Switch Kit
EPSK-1A	Class I, Group A - D Pressure Switch Kit
EPSK-2	Class II, Group E - G Pressure Switch Kit
GPSK-1	Class I, General Purpose Switch Kit
GPSK-2	Class II, General Purpose Switch Kit
RAH	Div. 1 Remote Alarm Horn
RAB-1	Div. 1 Remote Alarm Beacon
RAB-2	Div. 2 Remote Alarm Beacon
LCK	L Fitting Conduit Kit
TCK	T Fitting Conduit Kit
PIAD	Purgeable Instrument Access Door
TR-10	Tamper-Proof Regulator
TR-10G*	Tamper-Proof Regulator w/ Gauge
PR-10	Precision Regulator
PR-10G	Precision Regulator w/ Gauge

\* These items are provided as part of the nVent HOFFMAN Kit. \*\* Accessory items are available through Pepperl+Fuchs.

Please consult the Pepperl+Fuchs Customer Service Department for suitability of items for this assembly before purchase.

# Enclosure & Device Design

## Enclosure Design Requirements

1. All windows must be shatterproof and sized as small as possible.
2. All NFPA 496 required markings must be placed on or near **all** enclosure doors and covers.
3. The enclosure must withstand an internal pressure of ten (10) inches of water without sustaining permanent deformation and resist all corrosive elements in the surrounding atmosphere.
4. All lightweight objects in the enclosure, such as paper or insulation, must be firmly secured.
5. The enclosure should be constructed from materials such as metal or non-static polycarbonate to meet or exceed NEMA 4 or 12 performance requirements, but does not require third party approval.
6. The installation of obstructions or other barriers which block or impede the flow of protective gas must be avoided.
7. The creation of air pockets or other areas which trap flammable gases within the enclosure or devices must be avoided.
8. The enclosure should be located in an area where impact hazards are minimal.
9. If the enclosure is nonmetallic and contains equipment which utilizes or switches power loads greater than 2500 VA, it must be constructed from substantially noncombustible materials, such as materials designed to meet or exceed ANSI/UL94 ratings of 94 V-0 or 94 5V.

## Adjacent Enclosures

1. Adjacent enclosures must be protected by one of the following means:
  - a) purged or pressurized in series with the protected enclosure;
  - b) purged or pressurized separately; or
  - c) protected by other means; e.g. explosion proof enclosures, hermetically sealed devices or intrinsic safe circuits.
2. Adjacent purged or pressurized enclosures must be designed to meet all construction requirements above.

## Total Volume Calculation

1. The total volume of all pressurized enclosures, devices and wireways must be considered.
2. All enclosure, device and wireway volumes must be calculated without consideration of internally consumed space.

## Device Ventilation

1. Enclosed devices within the protected enclosure which do not exceed 1.22 cubic inches of free volume do not require ventilation to the protected enclosure.
2. If the free volume of an internal device exceeds 1.22 cubic inches it must be protected by one of the following means:
  - a) ventilated on the top and bottom sides with one (1) square inch of opening for each four hundred (400) cubic inches of volume within the internal protected enclosure, at a minimum diameter of one (1) quarter inch;
  - b) purged in series with the protected enclosure or be purged separately; or
  - c) protected by other means; e.g. explosion proof enclosures, hermetically sealed devices or intrinsic safe circuits.

## Temperature Limitations

1. The enclosure must have no surface area which exceeds 80 percent of the flammable or ignitable substance's auto-ignition temperature.
2. Internal devices which exceed this temperature must be protected by one of the following manners.
  - a) The device is enclosed in a chamber that is cULus or FM listed as a hermetically sealed device which prohibits the entrance of flammable or ignitable substance, and maintains a surface temperature below temperature limits.
  - b) It can be proven by testing that the devices will not ignite the substance involved.
  - c) The device is purged in a separate enclosure that bears an ETW (Enclosure Temperature Warning Nameplate). Devices may only be accessed after power has been removed and the device has been allowed to cool to safe temperature, or the area is positively known to be nonhazardous.

# Installation Overview

## Typical Left Hand Configuration Installation Diagram

Model 1002-WPS-LH Shown

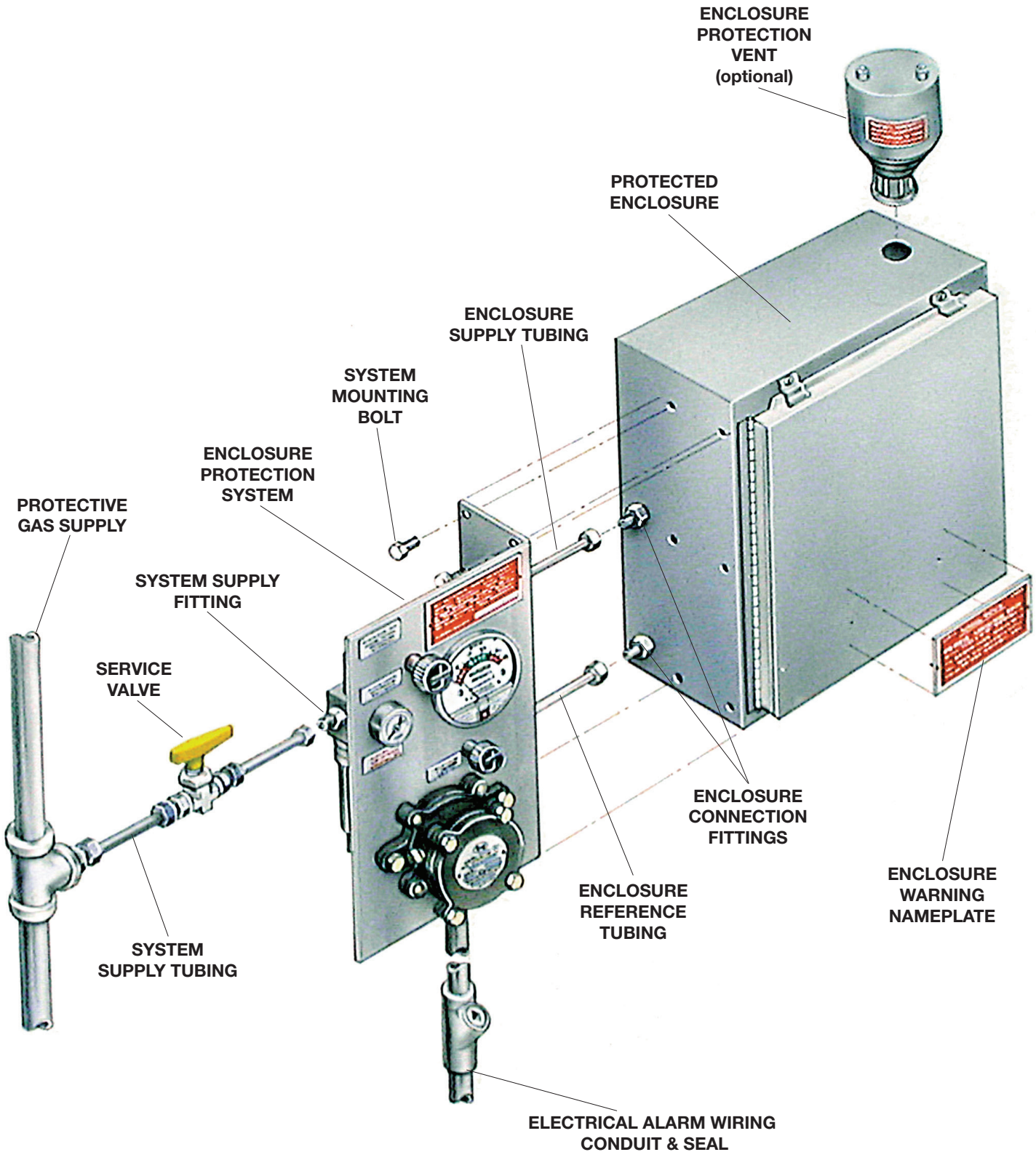

# Getting Started

## Establishing Connection Sizes, Lengths & Bends

### TYPICAL SINGLE PROTECTED ENCLOSURE CONNECTIONS

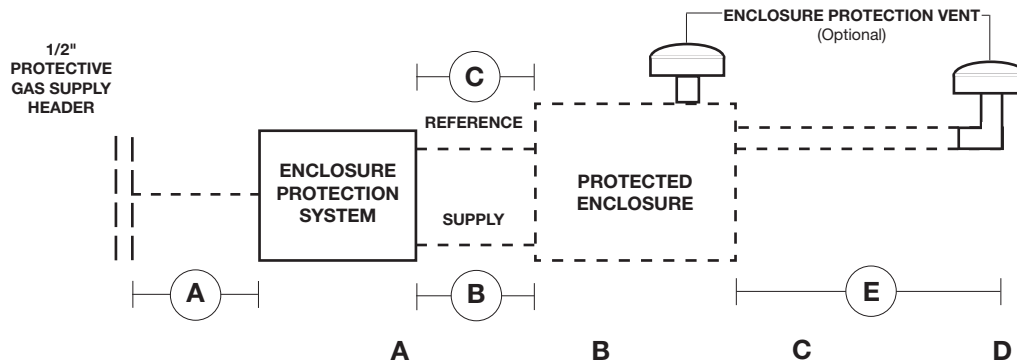

Description	System Supply Tubing	Enclosure Supply	Enclosure Reference	Multi - Enclosure Connections	Optional Remote Venting
<b>Tubing or Pipe Diameter</b>	1/4" O.D. Tubing Fully Reamed	1/4" O.D. Tubing Fully Reamed	1/4" O.D. Tubing Fully Reamed	1/2" I.D. Pipe Fully Reamed	1/2" I.D. Pipe Fully Reamed
<b>Maximum Tubing / Pipe Length and Maximum Number of Bends / Elbows</b>	20 Feet 10 Bends	5 Feet 5 Bends	20 Feet 10 Bends	10 Feet 5 Elbows	30 Feet 5 Elbows

### TYPICAL MULTIPLE PROTECTED ENCLOSURE CONNECTIONS

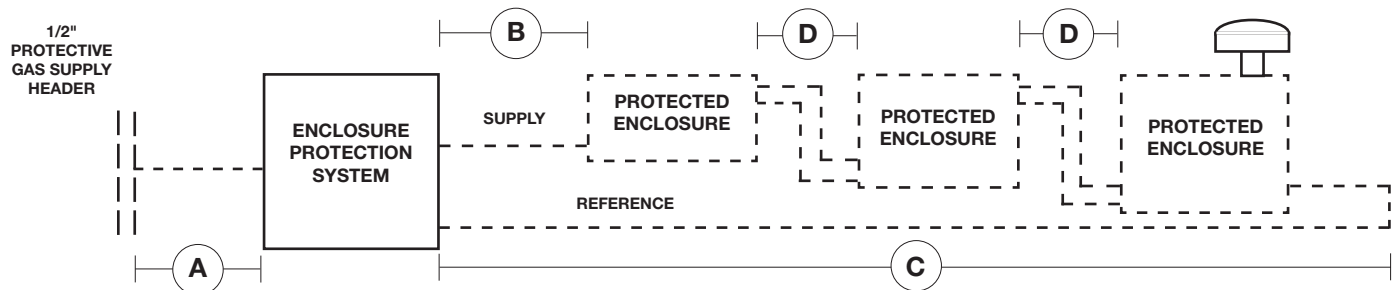

## HELPFUL HINTS

To ensure adequate protective gas flow to the protected enclosure(s), all piping and tubing must be fully reamed.

Precautions must be taken to prevent crimping and other damage to protective gas piping and tubing.

## Determining Enclosure Inlet & Outlet Connection Locations

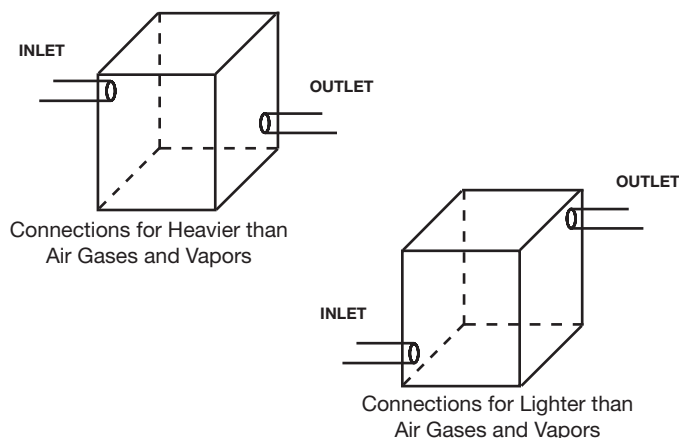

## HELPFUL HINTS

If flammable gases are lighter than air, the inlet connection to each enclosure must enter near a bottom corner. The outlet connection, for an optional enclosure protection vent or piping to an adjacent protected enclosure, must exit near an extreme opposite top corner.

If flammable gases are heavier than air, inlet and outlet connections must be reversed.

In all cases, the most prevalent gas must determine the location of inlet and outlet connections.

# System Mounting

## IMPORTANT NOTES

The system should be mounted at **EYE LEVEL**.

Care must be taken to ensure the system and all protruding components are clear of all enclosure accesses (doors and covers) and conduit, pipe, tubing or cable entries.

LH, RH, TM, BM and WM configurations are intended for mounting adjacent to the protected enclosure.

LH, RH, TM & BM configurations are also suitable for 2" schedule 40 pipe mounting. In addition, these configurations can be accessorized with an ECK (Enclosure Connection Kit). (See page 9)

Systems furnished with the ECK are not compatible for pipe mounting or multiple enclosure applications.

Determine the mounting configuration of your system using the diagrams on pages 10 & 11.

Remove and save the manila envelope (containing the enclosure warning nameplate) which may be taped to the outer surface of the mounting flange.

Although all systems are factory tested and calibrated, we strongly suggest a bench test of basic functions prior to installation.

## Mounting LH, RH, TM, BM & WM Configurations

### Surface mounting Systems with ECK accessory

1. Verify dimensions of the System's mounting holes and connection fittings in reference to the applicable drawing on pages 10 and 11.
2. Upon confirmation of dimensions, transfer mounting hole pattern from drawing to the intended surface.
3. Check for internal obstructions which could hinder bolt fastening and protective gas flow, drill and ream the mounting holes before mounting the system.
4. Remove locknuts on enclosure connection fittings.
5. Secure the system to the protected enclosure using one (1) SMK-1 mounting kit or equivalent - four (4) 1/4" x 3/4" stainless steel bolts, nuts and lock washers.
6. Install the locknuts on the enclosure connection fittings from inside of the protected enclosure, ensuring that fittings seat directly against enclosure through the system mounting plate flange.

### Surface mounting Systems without ECK accessory

1. Transfer hole pattern of System mounting plate to intended surface.
2. Check for obstructions hindering bolt fastening, drill and ream the mounting holes before mounting the system.
3. Secure the system to the enclosure, or other mounting surface, using one (1) SMK-1 mounting kit or equivalent - four (4) 1/4" x 3/4" stainless steel bolts, nuts and lock washers.

### Pipe mounting Systems without ECK accessory

1. Locate 2" schedule 40 pipe, (vertical for LH & RH, horizontal for TM & BM) within five (5) feet of protected enclosure.
2. Ensure system is mounted in a true vertical position, secure the system to pipe, using one (1) a PMK-1 mounting kit or equivalent - two (2) 1/4" x 2" stainless steel "U" bolts, nuts and lock washers.

## Mounting FM & PM Configurations

### HELPFUL HINTS

FM and PM configurations are designed to mount through a panel cutout one (1) inch smaller than the overall height and width of the system mounting plate, using clips and fasteners provided with the SMK-4 mounting kit. This design feature eliminates the need to drill the system mounting bolt holes in the protected enclosure.

FM configurations are intended for mounting adjacent to the protected enclosure.

PM configurations are intended for mounting through a cutout in the protected enclosure surface.

1. Transfer panel cutout pattern to the intended surface.
2. Check for obstructions which could prohibit bolt fastening or system pneumatic connections.
3. Cut panel cutout pattern on the intended surface.
4. Deburr all cutout surfaces.
5. Secure system to enclosure using SMK-4 or SMK-6 mounting kit, or equivalent 1/4" x 3/4" stainless steel nuts, bolts, mounting clips and lock washers.



# Special Mounting Information

## Typical Example of Factory Installed ECK & ILFK Accessories

### (ECK) - FACTORY INSTALLED ENCLOSURE CONNECTION KIT ACCESSORY

Provides factory installed tubing and fittings for enclosure supply and reference connections.

### (ILFK) - FACTORY INSTALLED IN-LINE FILTER KIT ACCESSORY

Provides an 8.5 oz. capacity, 40 micron protective gas supply filter, factory installed on the inlet side of the enclosure pressure control regulator.

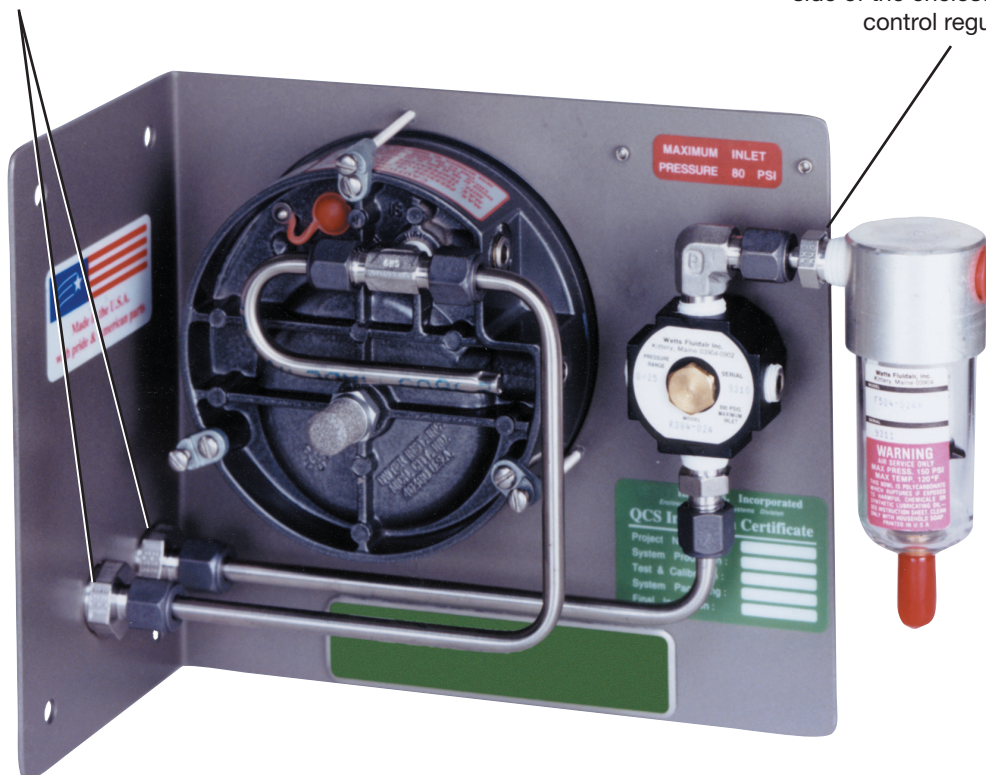

Model 1001A-LPS-LH shown

## Typical Examples of Surface, Pipe, Panel & Frame Mounted Systems



Typical Surface Mounted System  
(Model 1002-LPS-CI-Z-LH shown)

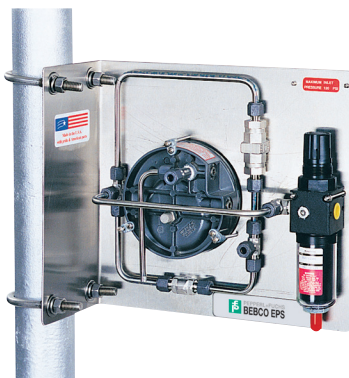

Typical Pipe Mounted System  
(Model 1002-LPS-CI-Z-LH shown)



Typical Panel/Frame Mounted System  
(Model 1002-LPS-CI-Z-PM shown)

# Mounting Plate Dimensions

Model 1001A

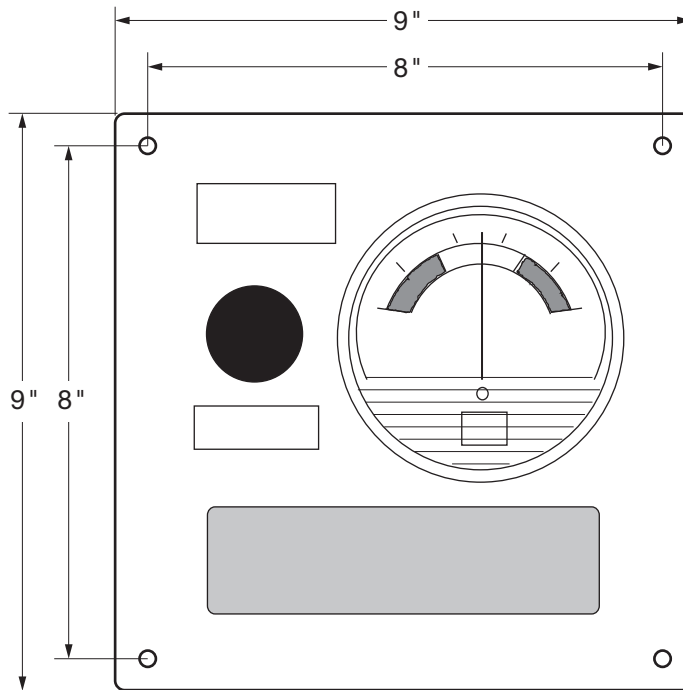

Face Plate

# Mounting Plate Dimensions (cont.)

Model 1001A

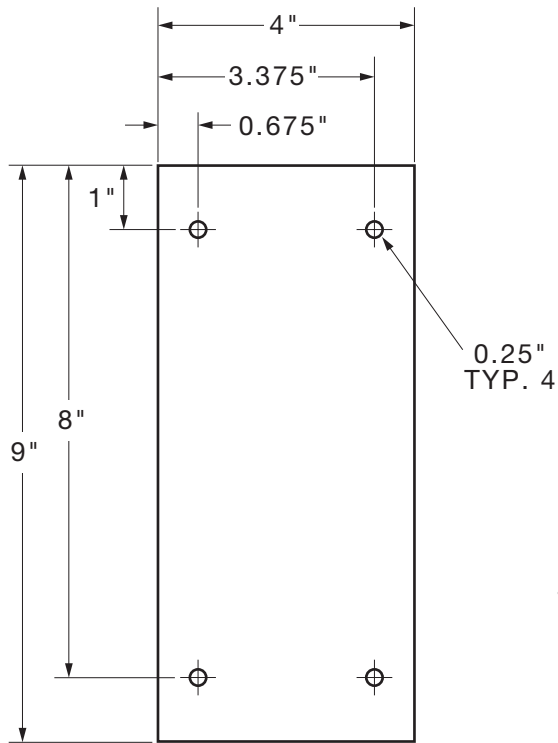

**Universal Flange  
Footprint**

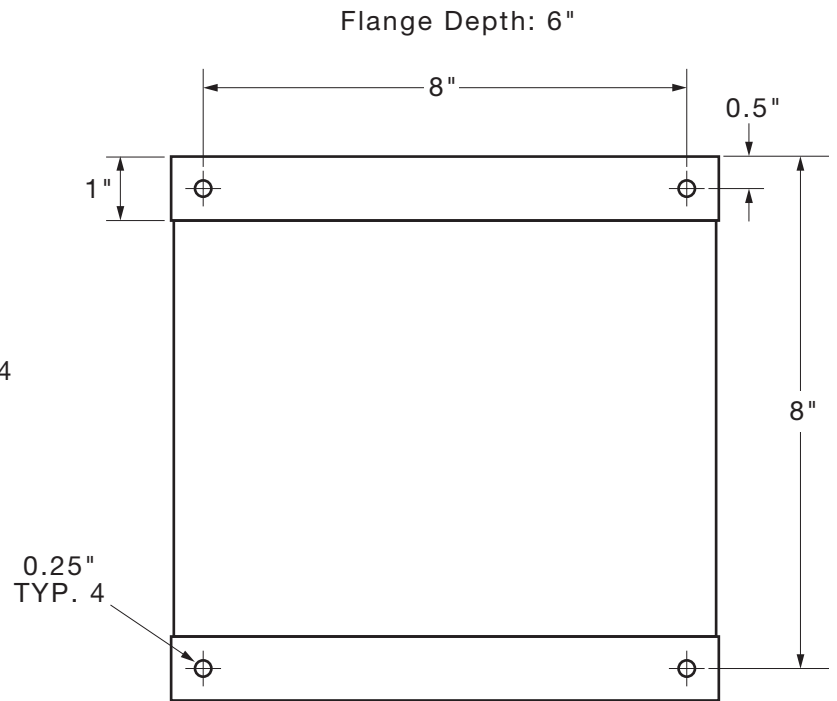

**Optional Wall Flange  
Footprint  
(only available from Pepperl+Fuchs)**

# Hardware Mounting

## Optional Enclosure Protection Vent

All configurations must be mounted in a true vertical position.

The vent must be located to provide access for routine testing of the vent's flapper assembly. A minimum 8" clearance is required below the vent opening.

1. Determine the vent's mounting configuration, i.e.; -00 vertical mount or -90 side mount. (see photos below)
2. Determine vent location and layout vent mounting hole on the protected enclosure. (as determined on page 7, "Getting Started")
3. Using a 0.875" hole saw or 1/2" conduit punch, drill and deburr the enclosure protection vent mounting hole.
4. Remove the hub mounting nut from the vent hub and place the hub, with O-ring intact, through the mounting hole. The O-ring must be on the outside of the protected enclosure.



EPV - 1 - SA - 00  
Top Mount



EPV - 1 - SA - 90  
Side Mount

## Warning Nameplate(s)

An EWN (Enclosure Warning Nameplate) must be located in a prominent position on or near **all** enclosure accesses (doors and covers).

One (1) EWN is provided with each system, located in the manila envelope taped to the mounting flange of the system. Additional EWN's are available from Pepperl+Fuchs.

All EWNs provide labeled spaces allowing the customer to mark the protected enclosure with: 1) a T Code (temperature identification number), 2) Class, Group and Division of surrounding area, and 3) NFPA pressurization Type X, Y or Z, as may be required by plant and local codes and is required by NFPA 496.

An ETW (Enclosure Temperature Warning nameplate) must be located in a prominent position on or near all enclosure accesses (doors and covers) when the temperature of an internal component exceeds 80 percent of the ignition temperature of the flammable vapor, gas or dust involved.

The ETW warns the operator to deenergize all equipment for a specified length of time, allowing the protected equipment to cool before opening the protected enclosure. The length of time required is determined by the customer and can be factory or field engraved.

All EWNs and ETWs are furnished with an adhesive back, but should also be riveted or screwed to the protected



Enclosure Warning Nameplate - Class I



Enclosure Warning Nameplate - Class II



Enclosure Temperature Warning Nameplate

# Pneumatic Tubing Requirements

## Protective Gas Supply Requirements

The protective gas supply to the protection system must be a clean, instrument quality compressed air or nitrogen and must contain no more than trace amounts of flammable gas, vapor or dust.

The protective gas supply compressor intake must originate in a nonhazardous location. Suction duct passing through a hazardous location and the protection system tubing and piping must be fabricated from noncombustible materials suitable for prevailing hazards and environmental conditions.

The protective gas supply must originate from a dedicated instrument quality compressed air header (1/2" pipe or larger), no farther than twenty (20) feet from the protection system. Local compressors and gas cylinders should not be used before consulting with Pepperl+Fuchs.

The protective gas supply to the protection system must be equipped with a tamper-proof regulator set at 5 psi maximum.

**Exception:** If the protected enclosure(s) is equipped with a Pepperl+Fuchs Enclosure Protection Vent, the protective gas supply to the protection system must not exceed 120 psi maximum, 5 psi minimum. (See page 4, "System



SC-4

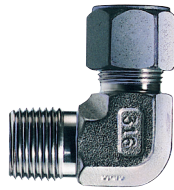

NC-4

SYSTEM SUPPLY FITTINGS



EFC-4



EBC-4

ENCLOSURE SUPPLY & REFERENCE FITTINGS



EPC-10

MULTIPLE ENCLOSURE CONNECTION FITTING

## Pneumatic Connection Requirements

ALL FITTINGS MAY BE CUSTOMER OR FACTORY FURNISHED

1. For system supply, one (1) SC-4 1/4" Male Straight Connector or one (1) NC-4 1/4" Male Elbow Connector or equivalent fitting per system.

**NOTE: Above fitting is required only if protection system is furnished with an optional In Line Filter Kit (Model ILFK) accessory. See photo on page 9**

One (1) Similar fitting which will connect the inert gas supply tubing to the inert gas supply header connection point and one (1) lot of 1/4" O.D., .035" wall thickness, welded or seamless stainless steel tubing.

2. For enclosure supply, one (1) EFC-4 1/4" Flush Connector, or one (1) EBC-4 1/4" Feed-Through Connector or equivalent fitting per system.
3. For enclosure reference, one (1) EFC-4 1/4" Flush Connector, or one (1) EBC-4 1/4" Feed-Through Connector or equivalent fitting per system.
4. One (1) lot of 1/4" O.D., .035" wall thickness, welded or seamless stainless steel tubing.

**NOTE: Above fittings and tubing are not required if System is furnished with an Enclosure Connection Kit (Model ECK) accessory. See photo on page 9**

5. For multiple enclosure connections, two (2) EPC-10 1/2" Pipe Mounting Hubs or equivalent and 1/2" 150# rated pipe couplings & unions per interconnection.

One (1) lot 150# rating 1/2" galvanized or aluminum pipe and fittings, fully reamed and unrestricted.

## PM Pneumatic Connection Requirements

In addition to item numbers 1, 4 and 5 above, the following fittings are required for all PM configurations.

1. For system supply on PM configurations, one (1) additional EBC-4 or equivalent 1/4" Through Bulkhead Fitting per system is required.
2. For atmospheric reference, one (1) PRB-4 or equivalent 1/4" female bulkhead fitting and stainless steel sintered element is required.



PRB-4

SYSTEM ATMOSPHERIC REFERENCE FITTING

# Tubing Installation

## HELPFUL HINTS

All work must be performed by technicians qualified in pneumatic tubing and electrical conduit installation.

Pepperl+Fuchs recommends the use of .035" wall thickness, welded or seamless stainless steel tubing. If flexible tubing is used, it must be installed in a manner which will protect it from damage and corrosion.

## Tubing LH, RH, TM, BM, WM & FM Configurations

### System Supply Connections

1. Select or install a protective gas supply header tap, fitted with the proper tube size fitting and located within twenty (20) feet of the enclosure protection system.
2. If a service valve is placed between the protective gas supply header and the enclosure protection system, it must be installed in close proximity of the protected enclosure and be labeled in accordance with section 2-11.4 of the NFPA 496, 1998 edition.
3. Select the appropriate fittings required to connect the protective gas supply to the protection system regulator as determined on page 13, "Pneumatic Connection Requirements".
4. Determine appropriate tubing route from the protective gas supply header to the protection system regulator.
5. Bend tubing using industrial grade benders, check tubing fit to ensure proper seating between the tubing and fittings. Fully ream all tubing ends.
6. Install tubing and tighten all fittings to fitting manufacturer's specifications. Secure tubing to appropriate structural supports as required.

### Enclosure Supply & Reference Connections

For systems supplied with an ECK (Enclosure Connection Kit), go to page 16 "Electrical Supply Requirements".

1. Choose location for the enclosure supply connection(s) based on the requirements on page 7, "Getting Started".
2. Place the enclosure reference connection fitting directly behind the enclosure protection system whenever possible. For systems protecting multiple enclosures in series, the enclosure reference connection fitting must be placed on the last enclosure in the series. (see page 7, "Getting Started")
3. Drill and deburr enclosure supply and reference fitting holes on the protected enclosure. Mount the fittings.
4. Determine appropriate route for the enclosure supply and reference tubing.
5. Bend tubing using industrial grade benders, check tubing fit to ensure proper seating between the tubing and fittings. Fully ream all tubing ends.
6. Install tubing and tighten all fittings to fitting manufacturer's specifications. Secure tubing to appropriate structural supports as required.

## Tubing PM Configurations

### Enclosure Bulkhead Fittings

1. Select the fittings required to install the System Supply, System Supply Bulkhead Fitting and Atmospheric Reference Bulkhead Fitting, (see page 13, "Pneumatic Tubing Requirements").
2. Choose location for the system supply bulkhead fitting. This fitting allows the protective gas supply to pass through the wall of a protected enclosure to the protection system's regulator supply inlet connection.
3. Choose location for the atmospheric reference bulkhead fitting. This fitting allows the enclosure pressure gauge to reference atmospheric pressure.
4. Drill and deburr system supply and reference bulkhead fitting holes in the protected enclosure. Mount the fittings.

### System Supply & Reference Connections

1. Select or install a protective gas supply header tap, fitted with the proper tube size fitting and located within twenty (20) feet of the enclosure protection system.
2. If a service valve is placed between the protective gas supply header and the protection system, it must be in close proximity of the protected enclosure and labeled in accordance with section 2-11.4 of the NFPA 496.
3. Determine appropriate tubing route from the protective gas supply header to the system supply bulkhead fitting.
4. Determine appropriate tubing route from the system supply bulkhead fitting to the protection system regulator.
5. Determine appropriate tubing route from the atmospheric reference bulkhead fitting to the enclosure pressure gauge's reference inlet connection.
6. Bend tubing using industrial grade benders, check tubing fit to ensure proper seating between the tubing and fittings. Fully ream all tubing ends.
7. Install tubing and tighten all fittings to fitting manufacturer's specifications. Secure tubing as required.

# Tubing Connection Diagrams

## LH, RH, TM, BM, WM & FM Configuration Connection Points & Pneumatic Diagram

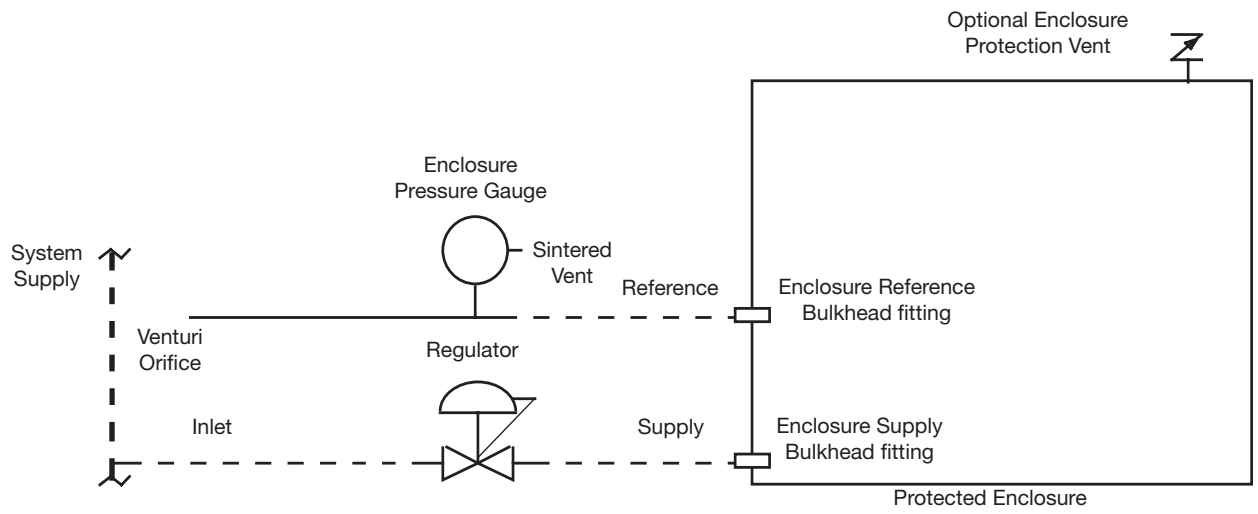

## PM Configuration Connection Points & Pneumatic Diagram

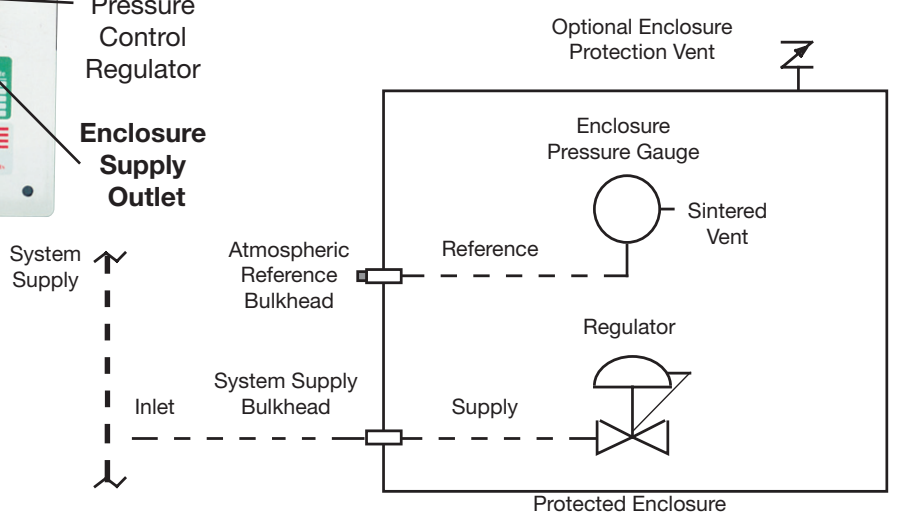
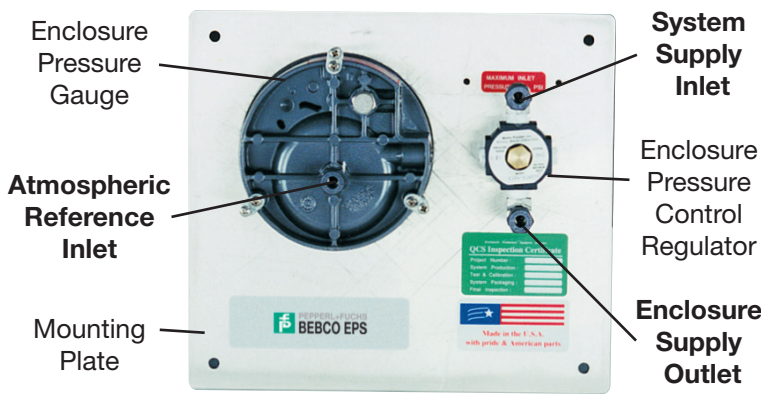

**HELPFUL HINT**  
 Pneumatic connections are bolded.

Subject to modifications without notice

Pepperl+Fuchs Group  
 www.pepperl-fuchs.com

USA: +1 330-486-0002  
 pa-info@us.pepperl-fuchs.com

Germany: +49 621-776-2222  
 pa-info@de.pepperl-fuchs.com

Copyright Pepperl+Fuchs

Singapore: +65-6779-9091  
 pa-info@sg.pepperl-fuchs.com

**PEPPERL+FUCHS**  
 PROTECTING YOUR PROCESS

# Electrical Supply Requirements

## General Wiring Requirements

### WARNING

**THIS DEVICE CONTAINS ELECTRICAL PARTS WHICH CAN CAUSE SHOCK OR INJURY**

All electrical connections, conduit and fittings on the protected enclosure must be suitable for the hazardous location in which they are installed. In addition, all conduit and wire must be installed in accordance with NEC articles 500-1, 500-2 or 500-3 as required and all relevant plant and local codes.

**Note:** Do not use seals on conduit used as a protected "wireway" to supply protective gas to adjacent protected enclosures. The same conduit can be utilized for both electrical and pneumatic service to an adjacent protected enclosure(s), provided the conduit is oversized to allow a minimum free clearance equal to or larger than the pipe size required between multiple enclosures as stated on page 7, "Getting Started".

## Enclosure Power Requirements

The protected enclosure(s) electrical power source must originate from a circuit breaker or fused disconnect suitable for the hazardous location in which it is installed. The switch must be located within fifty (50) feet of the protected enclosure(s) and the protection system and be properly marked.

## Alarm Signal Requirements

The protected enclosure(s) alarm signal may originate from the protected enclosure if the alarm signal is disconnected by the protected enclosure's circuit breaker or fused disconnect as stated in Enclosure Power Requirements above.

The protected enclosure(s) alarm signal power may also originate from outside of the protected enclosure. In this application, the protected enclosure may be used as a "wireway" to pass alarm signal wiring from the power source to the alarm device, if the wiring is isolated and properly labeled. In addition, appropriate conduit seals must be provided outside of the protected enclosure separately.

## IMPORTANT NOTE

**NFPA 496 requires the use of an alarm or an indicator to detect the loss of safe enclosure pressure. In addition, the NFPA 496 requires that if an indicator alone is utilized, a protective gas supply alarm must also be installed between the last valve in the protective gas supply and the protected enclosure. Therefore, the protective gas supply to all LPS Style systems must be equipped with the above mentioned protective gas supply alarm. Exception: Systems utilizing an EPSK or GPSK enclosure pressure loss alarm switch accessory will satisfy the above mentioned NFPA requirement.**

## Typical Enclosure Wiring Methods

Protected enclosures must be wired similar to explosion proof enclosures, in accordance with **Article 501-504** of the 1999 National Electric Code - **NFPA 70**.

Single conductor wiring must be placed in rigid metal conduit, seal-flex conduit or other mediums approved for use in the hazardous location surrounding the protected enclosure. Although the 1998 edition of NFPA 496 does not require conduit seals on pressurized enclosures in a division 2 area, Pepperl+Fuchs strongly recommends the use of a conduit seal as the most practical way to prevent excessive leakage through conduit connections.

While explosion proof enclosures require conduit seals on all cable entries, in accordance with **NFPA 70, Sections 501-5**, protected enclosure cable entries can be sealed in accordance with **Section 501-5** which permits the use of compression gland fittings or other sealed cable entry fittings, as opposed to approved conduit seals, if the wiring method is otherwise suitable for the hazardous location.

In conclusion, there are two primary goals. First, the installer should ensure all associated wiring and cable is protected by pressurization or other means, such as explosion proof conduit or intrinsic safety barriers. Secondly, the installer must ensure all associated conduit and wireways are sealed to conserve protective gas, unless they are used to supply protective gas to other enclosures or devices.

## Typical Enclosure Wiring Connections

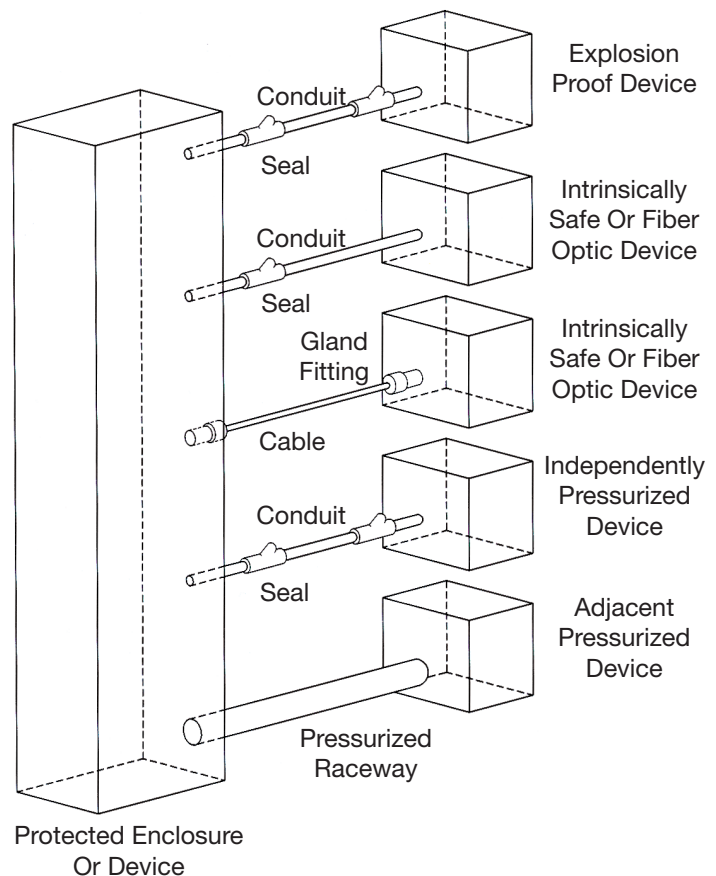



# Set-up Procedure

## HELPFUL HINTS

The term “Safe” pressure for purposes of this manual is defined as follows;

**Class I = a minimum .25 inch of water column pressure.**

**Class II = a minimum 1.0 inch of water column pressure.**

**Regulator may be in the locked position upon arrival.**

**To adjust regulator, pull handle to outward position.**

To test the vent’s operation, gently prod the vent flapper open with a soft pointed object, ( example: eraser end of a pencil) ensuring that the vent valve works freely. On vertically configured vents, this can be accomplished from within the protected enclosure. Side mounted -90 configured vents can be tested by removing the conduit plug at the bottom of the mounting tee. Multiple operations require only one test per day if enclosure is not opened or left unattended.

## Class I Purging Set-up

1. Close the Enclosure Pressure Control Regulator fully by turning counterclockwise (CCW).
2. Temporarily connect the inert gas supply to a 0 to 250 SCFH flowmeter. Connect the outlet of the flowmeter to the Enclosure Pressure Control Regulator.
3. Check operation of Enclosure Protection Vent (if utilized).
4. Seal enclosure(s) and adjust Enclosure Pressure Control Regulator by opening slowly clockwise (CW) to set a “Safe” pressure on the Enclosure Pressure Indicator.  
**NOTE:** If pressure setting is difficult to stabilize or set, (see page 20, “Troubleshooting Procedures”).
5. When safe enclosure pressure is stabilized, measure flow of inert gas supply through Protection System, to calculate required exchange time, based on the Class I exchange time chart.
6. Install and tighten all bolts on the pressure loss alarm switch (if utilized). Ensure the conduit is sealed with approved compounds. Energize power to Switch and alarm system (if utilized) and test the function of the alarm system.
7. Cease testing and remove test equipment (Flowmeter).
8. Connect the inert gas supply directly to the Enclosure Pressure Control Regulator.

### CLASS I VOLUME EXCHANGE TIME CHART

MEASURED FLOW	REQUIRED EXCHANGE TIME
0.10 SCFM / 6 SCFH	40 Minutes per Cubic Foot
0.25 SCFM / 15 SCFH	16 Minutes per Cubic Foot
0.50 SCFM / 30 SCFH	8 Minutes per Cubic Foot
0.75 SCFM / 45 SCFH	5.5 Minutes per Cubic Foot
1 SCFM / 60 SCFH	4 Minutes per Cubic Foot
2 SCFM / 120 SCFH	2 Minutes per Cubic Foot
3 SCFM / 180 SCFH	1.5 Minutes per Cubic Foot
4 SCFM / 240 SCFH or greater	1 Minute per Cubic Foot

**NOTE:** The volume exchange time chart is based on a four (4) enclosure volume exchange. Multiply the required exchange time above by 2.5 for applications requiring a ten (10) volume exchange (motors).

Regardless of enclosure volume or system flow rate, it is required that operators withhold power to the enclosure while inducing Class I exchange, for at least five (5) minutes. Normal exchange time calculations should be doubled if large obstructions block inert gas flow.

The Start-Up Instruction Nameplate Exchange Time Slot will be blank, but the unit may feature a set of direct factor nameplates with self-adhesive backing such as “TEN MINUTES”, for application to the start-up instructions, dependent on how the system was specified and purchased. Field modification of this nameplate, to show a direct factor, is acceptable as noted above if the method used to mark the nameplate does not deface the instructions listed. Materials used for the marking must be indelible and withstand prevailing environmental conditions.

## IMPORTANT NOTE

**Operators must secure wrist or stop watch to manually time Exchange Cycle for Class I applications.**

## Class II Pressurization Set-up

1. Close the Enclosure Pressure Control Regulator fully, by turning it counterclockwise (CCW).
2. Remove all traces of combustible dust from the protected enclosure.
3. Check operation of Enclosure Protection Vent (if utilized).
4. Seal enclosure(s) and adjust Enclosure Pressure Control Regulator by opening slowly clockwise (CW) to set a “Safe” pressure on the Enclosure Pressure Indicator.

**NOTE:** If pressure setting is difficult to stabilize or set, (see page 20, “Troubleshooting Procedures”).

5. Install and tighten all bolts on the pressure loss alarm switch (if utilized). Ensure the conduit is sealed with approved compounds. Energize power to Switch and alarm system (if utilized) and test the function of the alarm system.

# Operating Sequence

## WARNING

Do not exceed a “Safe” pressure with the Enclosure Pressure Control Regulator.

Operators must follow step-by-step sequence of the Start-Up Instructions Nameplate on the Protection System.

### Class I Purging Operation

With the inert gas supply connected, enclosure power deenergized and alarm system energized (if utilized).

1. Carefully read Start-Up Instruction Nameplate on system.
2. Check operation of the Enclosure Protection Vent (EPV-1, if utilized), opening it manually several times, (see page 17, “Helpful Hint”).
3. Seal protected enclosure(s).
4. Open Enclosure Pressure Control Regulator, by turning CW, to set Enclosure Pressure Indicator at “Safe” pressure, the Pressure Loss Alarm Switch should then activate to silence the alarm system (if utilized).
5. Ensure the Protection System Enclosure Pressure Indicator maintains a “Safe” pressure for one (1) minute.
6. Standby for the exchange time as specified on the Instruction Nameplate, then energize the protected enclosure power.
7. Ensure the Enclosure Pressure Indicator maintains a “Safe” pressure before leaving system unattended.

### Class II Pressurization Operation

With the inert gas supply connected, enclosure power deenergized and alarm system energized (if utilized) . .

1. Carefully read Start-Up Instruction Nameplate on system.
2. Check operation of the Enclosure Protection Vent (EPV-1, if utilized), opening it manually several times, (see page 17, “Helpful Hint”).
3. Remove all traces of combustible dust.
4. Seal protected enclosure(s).
5. Open Enclosure Pressure Control Regulator by turning CW to set Enclosure Pressure Indicator at “Safe” pressure, the Pressure Loss Alarm Switch should then activate to silence the alarm system (if utilized).
6. Ensure the Protection System Enclosure Pressure Indicator maintains a “Safe” pressure for one (1) minute.
7. Energize the protected enclosure power.
8. Ensure the Enclosure Pressure Indicator maintains a “Safe” pressure before leaving system unattended.

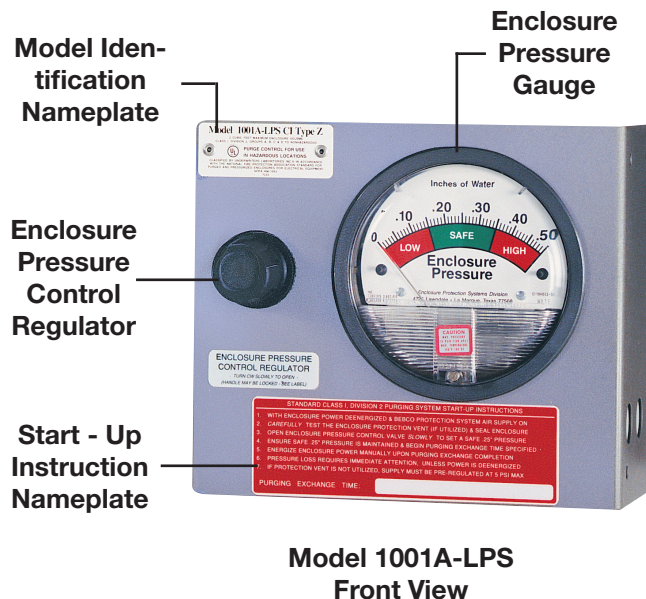

# Troubleshooting Procedures

Problem or Fault	Possible Causes	Corrective Action
Enclosure pressure control regulator will not hold a safe pressure.	Leakage around gasketing, covers, seams, piping and tubing connections, conduit connections and electrical conduit seals of the enclosure.	Tighten enclosure latches. Where tightening is not feasible, and gasketing materials are not practical, holes or gaps can be closed with silicone sealant applied from inside the protected enclosure.
Enclosure pressure indicator reading is difficult to stabilize.	Insufficient enclosure leakage or opening of the venturi orifice is crimped too small.	Remove the orifice, cut off the crimped end and ream the tube, then recrimp and reinstall the tube to note effect. As tube is shortened, reamed, and recrimped, sensitivity decreases, allowing easier adjustment of setpoint on the enclosure.
Enclosure Pressure Indicator "Drifts" up or down from the "Safe" pressure setting.	Application involves a small, tightly sealed enclosure and/or a fluctuating protective gas supply.	Pre-regulate the protective gas supply upstream of the enclosure protection system to 5 psi maximum.  For dramatic fluctuations in the protective gas supply, it may be necessary to utilize a self-relieving low flow precision regulator to pre-regulate the protective gas supply.
Enclosure pressure loss alarm switch does not appear to be operating (if utilized).	Pressure switch is out of calibration.	Calibrate by slowly adjusting counterclockwise to decrease the setpoint, and clockwise to raise the setpoint. (Do not attempt to calibrate the switch until all efforts to make the switch respond properly have failed)
Problems persists, or if the system does not appear to be operating properly.	Persisting problems	Contact nVent HOFFMAN at (763) 422-2211 for more information.

This section covers the most common problems documented with these systems. Any problems not covered in this section should be addressed directly to our factory. Please address all service needs to nVent HOFFMAN (763) 422-2211.

# Warranty Terms and Conditions

## PEPPERL+FUCHS STANDARD 24-MONTH WARRANTY

- Limited Warranty.** Pepperl + Fuchs, Inc. ("P+F") warrants Purge Units and components for Purge Units manufactured by P+F ("Product" or "Products") to be free from defects in material and workmanship under Normal Use for a period of twenty-four (24) months from the date of shipment of such Products from P+F's warehouse or place of manufacture (or from P+F's authorized representative or distributor). Only the original purchaser of such Products (the "Customer") shall be entitled to the benefit of the foregoing Limited Warranty. No representative, agent or salesman of P+F is authorized to give or provide any warranty or make any representation contrary to or in addition to the foregoing Limited Warranty.
- Inspection and Claims.** Customer must inspect and test all Products upon receipt. All claims under the Limited Warranty provided herein must be made within thirty (30) days of the discovery of the defect. Customer must obtain shipping instructions from P+F prior to returning any Product, which Product must be returned at Customer's expense in accordance with P+F's instructions.
- Limitations and Exclusions.** "Normal Use" shall mean use and operation within rated capacities, at the correct voltage, and with any required maintenance as provided in the applicable P+F Operating Manuals. The Limited Warranty provided herein does not apply to (i) any Products which have been altered or modified in any way or disassembled by the Customer or anyone else, (ii) any Products which have been subject to misuse, negligence or accident, or improperly installed, changed, substituted or replaced, (iii) any part or component not manufactured by P+F, or (iv) any part or component that is subject to wear or consumption. For parts or components not manufactured by P+F, the Customer or any other user or owner shall have only the warranty provided by the manufacturer of such part or component. The Limited Warranty set forth herein is also subject to the following:
  - The Limited Warranty is limited to electronic and mechanical performance only, as expressly detailed in the product specifications, and does not apply to cosmetic appearance;
  - The Limited Warranty shall not apply to any cables attached to, or integrated with, any Products.
  - The Limited Warranty shall not apply to any Products which are stored, or utilized, in harsh environmental or electrical conditions outside P+F's written specifications.

THE LIMITED WARRANTY SET FORTH HEREIN IS THE ONLY WARRANTY MADE BY P+F WITH RESPECT TO THE PRODUCTS. IT IS EXPRESSLY AGREED AND UNDERSTOOD THAT P+F MAKES NO WARRANTY OF MERCHANTABILITY OR FITNESS FOR A PARTICULAR PURPOSE. EXCEPT FOR THE LIMITED WARRANTY SET FORTH HEREIN, THERE IS NO OTHER WARRANTY, EXPRESS, IMPLIED OR STATUTORY; AND THERE IS NO AFFIRMATION OF FACT OR PROMISE BY P+F WITH REFERENCE TO THE PRODUCTS. IN NO EVENT SHALL P+F BE LIABLE FOR ACTUAL OR ANTICIPATED LOSS PROFITS OR FOR INCIDENTAL OR CONSEQUENTIAL OR PUNITIVE DAMAGES OR FOR DAMAGES RESULTING FROM BUSINESS INTERRUPTION, OR INJURY OR DEATH OF PERSONS, OR INJURY TO PROPERTY. P+F'S LIABILITY ON ANY CLAIM OF ANY KIND ARISING OUT OF, CONNECTED WITH OR RESULTING FROM THE DESIGN, MANUFACTURE, SALE, REPAIR OR OPERATION OF A PRODUCT, SHALL NOT EXCEED THE PRICE ALLOCABLE TO THAT PRODUCT OR THE PART THEREOF WHICH GIVES RISE TO THE CLAIM. THE REMEDY SET FORTH IN THIS LIMITED WARRANTY CONSTITUTES THE SOLE AND EXCLUSIVE REMEDY OF THE CUSTOMER. P+F SHALL NOT BE LIABLE FOR PENALTIES OF ANY DESCRIPTION.

- Limitation of Remedies.** In the event of P+F's liability, whether on this Limited Warranty or based on contract, tort (including, but not limited to, negligence and strict liability) or otherwise, Customer's sole and exclusive remedy will be limited to, at P+F's option, the repair or replacement (f/o/b P+F's place of manufacture) by P+F of any non-conforming items for which claim is made by Customer in accordance with paragraph 2, or the repayment of the portion of the purchase price paid by Customer attributable to the non-conforming item.
- Responsibility of Customer: Safety and Protection Precautions.** P+F takes great care to design and build reliable and dependable Products; however, some Products can fail eventually. Customer must take precautions to design its equipment to prevent property damage and personal injury in the unlikely event of a failure. AS A MATTER OF POLICY, P+F DOES NOT RECOMMEND THE INSTALLATION OF PRODUCTS AS THE SOLE DEVICE FOR THE PROTECTION OF PERSONNEL OR PROPERTY AND, THEREFORE, THE CUSTOMER SHOULD BUILD IN REDUNDANCY OR DUAL CONTROL USING APPROVED SAFETY DEVICES FOR THESE APPLICATIONS.
- Conflicts.** In the event there is any conflict between the provisions of this Limited Warranty and any provisions contained in any orders, offers, acceptances or other writings or statements provided or made by Customer to P+F, the provisions of this Limited Warranty shall prevail, and the contract between P+F and the Customer shall be deemed formed only upon the provisions set forth in this Limited Warranty, and any additional or conflicting provision inserted by Customer shall be of no force or effect.



CUSTOMER NOTES



**SYSTEMS IDENTIFICATION & APPLICATION INFORMATION**

**Date of Installation**

**Unit Serial #**

**Item**

**Customer P.O.#**

**Customer Project#**

**Service**

**Type**

**Features**

**Application**

**NOTES:**

**Local Sales Representative**