



ERICO INTERNATIONAL CORPORATION
34600 Solon Road
Solon, Ohio 44139
800 248-2677

www.erico.com
michael.ugalde@nvent.com
michael.kolta@nvent.com
ward.judson@nvent.com

nVent LENTON Mechanical Splice System for Steel Reinforcing Bars in Concrete

CSI Section:
03 21 00 – Reinforced Steel

1.0 RECOGNITION

nVent LENTON Mechanical Splice System recognized in this report has been evaluated for use as mechanical splices for deformed steel reinforcing bars (rebar) in reinforced concrete structural members. The structural properties of the nVent LENTON Mechanical Splice System comply with the intent of the provisions of the following codes and regulations:

- 2021, 2018, 2015, 2012, 2009, 2006, and 2003 International Building Code (IBC®)
- 2021, 2018, 2015, 2012, 2009, 2006, and 2003 International Residential Code (IRC®)
- Building Code Requirements for Structural Concrete (ACI 318-19, -14, -11, -08, -05, -02)
- 2023 and 2020 City of Los Angeles Building Code (LABC) – attached Supplement
- 2023 and 2020 City of Los Angeles Residential Code (LARC) – attached Supplement

2.0 LIMITATIONS

Use of the nVent LENTON mechanical couplers recognized in this report is subject to the following limitations:

- 2.1** Couplers shall be installed in accordance with the applicable code, the manufacturer’s instructions, and this report. Where conflicts occur, the more restrictive governs.
- 2.2** Splice locations shall comply with applicable code requirements and be noted on plans approved by the building official.
- 2.3** Where required, special inspection shall be provided in accordance with Chapter 17 of the IBC®. Duties of the special inspector include verifying:

- Grade and size of rebar.
- Coupler identification.
- Position of the couplers.
- Installation of the couplers to the rebar.

2.4 The threaded rebar used with nVent LENTON mechanical splice couplers shall be fabricated by nVent or an approved fabricator complying with Section 3.3.1 of this report.

2.5 Mechanical couplers may be used on epoxy-coated or galvanized bars prior to rebar threading or in a manner so as to not interfere with proper thread engagement. All threads of the coupler and rebar are to be free of rust, adhered concrete, epoxy, and galvanizing coating, and all debris at the time of coupling.

2.6 Under the 2021 IBC or IRC, mechanical splice systems used in special moment frames and special structural walls shall be designed in accordance with ACI 318-19 18.2.7.

2.7 Under the 2021 IBC or IRC, only Type 2 mechanical splices of ASTM A706 Grade 60 reinforcement, or ASTM A615 Grade 60 reinforcement satisfying the requirements of ACI 318-19 Section 20.2.2.5(b), shall be permitted in regions within a distance equal to twice the member depth from the column or beam face for special moment frames or from critical sections where yielding of the rebar occurs as a result of lateral displacements beyond the linear range of behavior in accordance with ACI 318-19 18.2.7.2.

2.8 Under the 2021 IBC or IRC, mechanical splice systems intermediate precast structural wall connections shall be designed in accordance with ACI 318-19 18.5.

2.9 Under the IBC or IRC, mechanical splice systems used in special moment frames constructed using precast concrete shall be designed in accordance with ACI 318-19 and -14 Section 18.9.2.1 (ACI 318-11 and -08 Chapter 21).

2.10 Under the 2021 IBC or IRC, Grade 80 reinforcement shall not be used as mechanical splices to transfer forces between the diaphragm and the vertical elements of the seismic-force-resisting system in accordance with ACI 318-19 18.12.7.4.

2.11 Under the 2021, 2018, and 2015 IBC or IRC, deformed steel reinforcing bars used with nVent LENTON mechanical splice systems shall comply with ACI 318-19 and -14 Section 20.2.2.4 and Table 20.2.2.4(a) for the intended structural usage and application.

2.12 Under the 2021 IBC, for structures regulated by Chapter 18 of ACI 318-19 (as required by 2021 IBC Section 1905.1),

The product described in this Uniform Evaluation Service (UES) Report has been evaluated as an alternative material, design or method of construction in order to satisfy and comply with the intent of the provision of the code, as noted in this report, and for at least equivalence to that prescribed in the code in quality, strength, effectiveness, fire resistance, durability and safety, as applicable, in accordance with IBC Section 104.11. This document shall only be reproduced in its entirety.





to splice deformed reinforcing bars resisting earthquake-induced flexure, axial force, or both, in special seismic systems and anchor reinforcement in Seismic Design Categories (SDC) C, D, E, and F, with the nVent LENTON Mechanical Splice Systems, mill certificates of reinforcing bars shall be submitted to the building official as evidence that the steel reinforcing bars comply with ACI 318-19 Section 20.2.2.5.

2.13 Under the 2018 IBC, for structures regulated by Chapter 18 of ACI 318-14 (as required by 2018 IBC Section 1905.1), to splice deformed reinforcing bars resisting earthquake-induced flexure, axial force, or both, in special moment frames, special structural walls, and all components of special structural walls including coupling beams and wall piers, with the nVent LENTON Mechanical Splice Systems, mill certificates of reinforcing bars shall be submitted to the building official as evidence that the steel reinforcing bars comply with ACI 318-14 Section 20.2.2.5.

2.14 Under the 2015 IBC, for structures regulated by Chapter 18 of ACI 318-14 (as required by 2015 IBC Section 1905.1), to splice deformed reinforcing bars resisting earthquake-induced flexure, axial force, or both, in special moment frames, special structural walls, and all components of special structural walls including coupling beams and wall piers, with the nVent LENTON Mechanical Splice Systems, mill certificates of reinforcing bars shall be submitted to the building official as evidence that the steel reinforcing bars comply with ACI 318-14 Section 20.2.2.5.

2.15 Under the 2012 IBC, for structures regulated by Chapter 21 of ACI 318-11 (as required by 2012 IBC Section 1905.1), to splice deformed reinforcing bars resisting earthquake-induced flexure, axial force, or both, in special moment frames, special structural walls, and all components of special structural walls including coupling beams and wall piers, with the nVent LENTON Mechanical Splice Systems, mill certificates of reinforcing bars shall be submitted to the building official as evidence that the steel reinforcing bars comply with ACI 318-11 Section 21.1.5.2.

2.16 Under the 2009 IBC, for structures regulated by Chapter 21 of ACI 318-08 (as required by 2009 IBC Section 1908.1), to splice deformed reinforcing bars resisting earthquake-induced flexural and axial forces in frame members, structural walls, and coupling beams, with the nVent LENTON Mechanical Splice Systems, mill certificates of reinforcing bars shall be submitted to the building official as evidence that the steel reinforcing bars comply with ACI 318-08 Section 21.1.5.2.

2.17 nVent LENTON mechanical couplers recognized in this report are produced in Solon, OH.

3.0 PRODUCT USE

3.1 General: nVent LENTON mechanical couplers for splicing deformed steel reinforcing bars (rebar) transfer

tension and compression forces in reinforced concrete structural members. The nVent LENTON splice systems recognized in this report comply with the requirements of the IBC and ACI 318-19 and -14 Sections 25.5.7 and 18.2.7 (ACI 318-11 Sections 12.14.3 and 21.1.6), for use as tension and compression mechanical splices for deformed steel reinforcing bar (rebar). The nVent LENTON system complies with both Type 1 and Type 2 mechanical splice requirements in accordance with ACI 318-19 and -14 Section 18.2.7.1 (ACI 318-11 Section 21.1.6.1) as shown in [Tables 1](#) to 20 of this report. The scope of applicability for steel reinforcing bars conforming with Grade 75 only applies when used with ASTM A615-18 or older editions. The nVent LENTON mechanical couplers consist of the following:

- nVent LENTON Standard couplers (A2 & A12), nVent LENTON Standard Transition couplers (A2 & A12), nVent LENTON Form Saver (SA), nVent LENTON Position couplers (P9 & P8) couplers for ASTM A615 Grades 60, 75, and 80 bars; or ASTM A706 Grades 60 and 80 bars.
- nVent LENTON Form Saver (FS) couplers for ASTM A615 Grades 60 and 75 bars; or ASTM A706 Grade 60 bars.
- nVent LENTON Lock (B1) couplers for ASTM A615 Grades 60 and 75 bars; or ASTM A706 Grade 60 bars.
- nVent LENTON Lock (S1) couplers for ASTM A615 Grade 60 or ASTM A706 Grade 60 bars.
- nVent LENTON Interlok (LK) for ASTM A615 Grade 60, 75, and 80 bars; or ASTM A706 Grade 60 and 80 bars.
- nVent LENTON weldable half couplers (C2 & C3J) for ASTM A615 Grade 60, 75, and 80 bars; or A706 Grade 60 and 80 bars.
- nVent LENTON Ultimate standard couplers (FT12 & MT12), nVent LENTON Ultimate transition couplers (FT12 & MT12), and nVent LENTON Ultimate position couplers (PT15, MS15, & MT12), for ASTM A615 Grades 60, 75, and 80 bars; or ASTM A706 Grades 60 and 80 bars.
- nVent LENTON Connect (B12) couplers for ASTM A615 Grade 60 or ASTM A706 Grade 60 bars.
- nVent LENTON Connect (S2) couplers for ASTM A615 Grade 60 or ASTM A706 Grade 60 bars.
- nVent LENTON Connect (B22) couplers for ASTM A615 Grade 60, 75, and 80 bars, or ASTM A706 Grade 60 and 80 bars.

3.2 Design: nVent LENTON couplers shall be installed in accordance with the applicable code, this evaluation report, and the manufacturer's installation instructions. Where conflicts occur, the more restrictive shall govern. Splice locations shall be detailed on the plans approved by the building official. Minimum concrete cover shall be in accordance with applicable codes and measured from the outer surface of the connecting device or as defined by the registered design professional. Type 2 mechanical splices are permitted in any location within a member as allowed



by the IBC, IRC, and ACI 318 in all seismic design categories.

3.3 Installation: Installation instructions are supplied with the product and/or are available on the nVent website (www.erico.com) and as described in Sections 3.4 through 3.16 of this report. Where conflicts occur, the more restrictive shall govern.

3.3.1 Specially prepared ends of rebar shall be prepared in either the nVent facility or the facility of a fabricator approved by the building official and nVent as required in accordance with Section 1704.2.5.1 of the 2021, 2018, or 2015 IBC, Section 1704.2.5.2 of the 2012 IBC, or Section 1704.2.2 of the 2009 IBC, as applicable. The fabricator shall demonstrate the following items to the satisfaction of the building official for each nVent LENTON coupler series and steel reinforcing bar size:

- A) The fabricator prepares the ends of the steel reinforcing bar as required by nVent in a manner consistent with the qualifying test specimens. A description of the method of preparing the rebar ends is found at www.erico.com.
- B) For Type 2 or 2HS (only applicable to LENTON B22 Couplers with bar size No. 4 to 7) splices, connections of each steel reinforcing bar using the fabricator-prepared steel reinforcing bars, tested in monotonic tension, shall develop 100 percent of the specified tensile strength (f_u) of the steel reinforcing bar and 125 percent of the specified yield strength (f_y) of the reinforcing bar for use under the IBC and IRC. The Type 2HS (only applicable to LENTON B22 Couplers with bar size No. 4 to 7) splice shall additionally develop strain in tension in the reinforcing bar as specified in ACI 318-19 Table 20.2.1.3(c). This requirement may be demonstrated in test report(s) submitted to the building official.
- C) For Type 1 splices, connections of each steel reinforcing bar using fabricator-prepared steel reinforcing bars, tested in monotonic tension, shall develop at least 125 percent of the specified yield strength (f_y) of the steel reinforcing bars. This requirement may be demonstrated in test report(s) submitted to the building official.

3.4 nVent LENTON Standard Coupler (A2 & A12) (illustrated below)

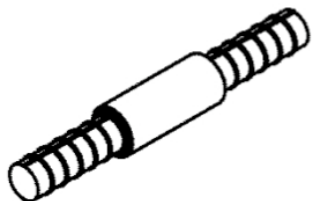

nVent LENTON standard coupler is used to connect bars where at least one bar is able to rotate freely. For field installation of the standard coupler, the thread protector is removed from the threaded rebar end, which is inspected for cleanliness and damage. In some cases, the coupler is fastened to the rebar at the fabrication facility to protect the threads. A wired brush should be used to remove rust and adhered concrete from the threads. Coupler is then screwed onto the threaded end of the rebar to be spliced and tightened by hand. The second rebar is then inserted into the coupler and rotated until hand-tight. The connection is then tightened per the manufacturer’s instructions.

3.5 nVent LENTON Standard Transition Coupler (A2 & A12) (illustrated below)



nVent LENTON Standard Transition coupler is similar to the Standard coupler, except the coupler is designed to connect rebars of different sizes. Installation for transition couplers is the same as that for standard couplers as described in Section 3.4 of this report.

3.6 nVent LENTON Form Saver Coupler (SA & FS) (illustrated below)

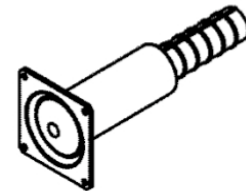

nVent LENTON Form Saver coupler is the same in terms of form and function as the standard coupler, except that the SA or FS coupler type has a non-structural form mounting plate attached to the end of the coupler. The Mounting plate simply provides a method of securing the SA or FS coupler type and attached bar to the formwork. An internal thread protector is installed to protect the Form Saver coupler’s internal threads. Form Saver FS coupler type is attached to the rebar by a friction forging process, whereby the rebar is attached to the coupler by forcing the components together while the coupler is revolving at a specific rate of speed. The other end of the Form Saver FS coupler type accepts rebar with tapered threads. Unlike the FS coupler type, the Form Saver SA coupler type accepts rebar with tapered threads at each end. As with the FS coupler type, the SA coupler type has a mounting plate that is attached to one end of the coupler. To install the Form Saver (SA or FS) coupler assembly, the mounting plate is used to position and secure the coupler types on the formwork. Upon completion of the concrete pour and removal of the formwork where the SA or FS coupler type is attached, the protectors are removed from



both the rebar and the coupler. Taper threaded male rebar of the proper size is then screwed into the exposed end of the Form Saver SA or FS coupler type. The connection is then tightened per the manufacturer’s instructions. Note: For identification purposes, the face of the Form Saver SA or FS coupler type mounting plate, which is exposed when the formwork is removed, has nVent LENTON coupler bar-size information stamped on the surface.

3.7 nVent LENTON Position Coupler (P9 & P8) (illustrated below)

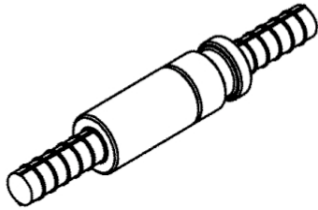

nVent LENTON Position coupler is used to connect curved or bent bars as well as straight bars that shall be held in a predetermined position during the connection process. Couplers may also be used where neither bar is free to rotate. All nVent LENTON Position couplers are manufactured to allow the coupler to rotate. The connection is tightened per the manufacturer’s instructions. In addition, position couplers are designed to accommodate rebars of different sizes.

3.8 nVent LENTON Lock Coupler (B1) (illustrated below):

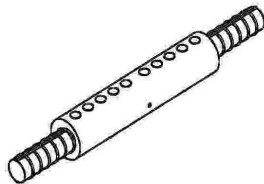

nVent LENTON Lock coupler is used to connect two bars mechanically. One or both rebars are inserted into the coupler in a predetermined position and the bolts are tightened in accordance with the manufacturer’s instructions. As long as the torque values are achieved, the bolt heads are not required to shear off. Unsheared bolt heads may be cut off if concrete cover is an issue. Additional details are found in the manufacturer’s installation instructions. In addition to connecting the same bar size to the same bar size, the nVent LENTON Lock coupler may also be used to:

- Connect the same size bar to the same size bar where both bars are one size smaller than the size identified on the coupler.
- Transition from the bar size identified on the coupler to the next smaller bar size.
- Transition from the bar size identified on the LL25B1 and LL32B1 couplers to two steps smaller bar size.

3.9 nVent LENTON Lock Coupler (S1) (illustrated below):

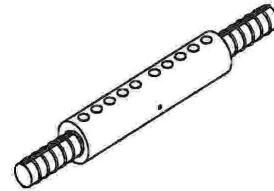

nVent LENTON Lock coupler is used to connect two bars mechanically. One or both rebars are inserted into the coupler in a predetermined position and the bolts are tightened in accordance with the manufacturer’s instructions. As long as the torque values are achieved, the bolt heads are not required to shear off. Unsheared bolt heads may be cut off if concrete cover is an issue. Additional details are found in the manufacturer’s instructions. In addition to connecting the same bar size to the same bar size, the nVent LENTON Lock coupler may also be used to:

- Connect same size bar to same size bar where both bars are one size smaller than the size identified on the coupler, and
- Transition from the bar size identified on the coupler to the next smaller bar size.
- Transition from the bar size identified on the LL25S1 and LL32S1 couplers to two steps smaller bar size.

3.10 nVent LENTON Interlok (LK) (illustrated below):

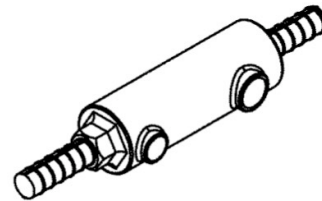

nVent LENTON Interlok coupler is cylindrical, with one end threaded to receive tapered threaded rebar and the opposite end machined with internal annular ridges that are spaced approximately 1 inch (25.4 mm) on center. Interlok coupler shall be installed in accordance with the IBC or IRC, the evaluation report, and the manufacturer’s installation instructions. The system consists of a coupler and grout from nVent. The available grouts are HY10L and HY15LM. The threaded end of the coupler is machined with a LENTON taper thread. A matching nVent LENTON tapered threaded piece of rebar is inserted into this end of the Interlok coupler and rotated until hand-tight. This portion of the connection is then tightened per the manufacturer’s instructions. The opposite end of the sleeve is open to receive the reinforcing steel of the adjoining precast structural member or projecting dowel. Pouring or pumping grout into the sleeve subsequently completes the connection. Temperatures during grouting shall range between 32°F and 100°F (0°C and 38°C). For HY15LM, additives are available to extend the temperature range down to 20°F and up to 122°F (-7°C to

50°C). Grout shall be mixed with water quantities determined from trial batches in accordance with Section 4.2.2 of this report. All oil, dirt, moisture, and other debris shall be removed from the coupler and other areas to be grouted. Mixed grout shall be either poured or pumped into the Interlok coupler. All spaces within the coupler shall be fully grouted. All spliced joints shall be adequately braced and supported to prevent movement of the rebar within the coupler. Braces are left in place for at least 24 hours, until the grout has attained a minimum compressive strength of 3,000 psi (20.7 MPa). Compression tests consist of 2-inch (51 mm) cubes tested in accordance with ASTM C109.

3.11 nVent LENTON Weldable Half Coupler (C2 & C3J) (illustrated below):

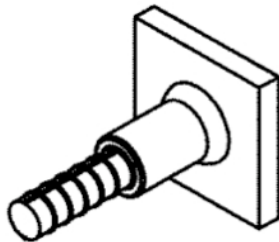

nVent LENTON weldable half coupler provides a mechanical means of connecting rebar to structural steel plates and shapes. The coupler is manufactured from weldable grades of material. One end of the coupler is machined with an nVent LENTON taper thread and the opposite side is prepared for welding. Weld shall be designed by a registered design professional in accordance with American Welding Society (AWS) standards. The connection is then tightened per the manufacturer’s instructions.

3.12 nVent LENTON Ultimate Standard Coupler (FT12 & MT12) (illustrated below):

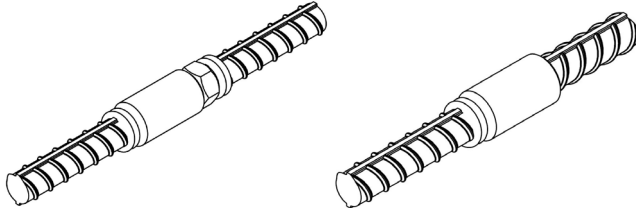

nVent LENTON Ultimate standard coupler is used to connect bars where at least one bar is able to rotate freely. The coupler consists of two components: female taper threaded (FT12) and male taper threaded (MT12). The FT12 and MT12 components are attached to the connecting rebars by a friction forging process. Alternately, the MT12 component may be substituted by rebar with nVent LENTON tapered threads (illustration shown on the right). One or both connecting bars are rotated until hand-tight. The connection is tightened per manufacturer’s instructions. In addition, Ultimate standard couplers are designed to accommodate rebars of different sizes.

3.13 nVent LENTON Ultimate Transition Coupler (FT12 & MT12) (illustrated below):

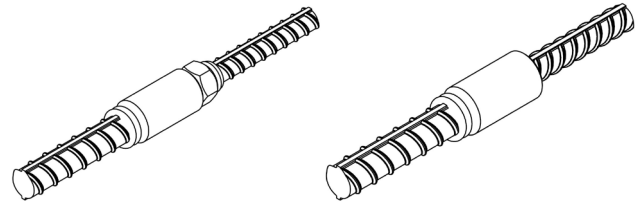

nVent LENTON Ultimate transition coupler is similar to the Ultimate standard coupler except the coupler is designed to connect rebars of different sizes. The MT12 component may be substituted by rebar with nVent LENTON tapered threads (illustration shown on the right). Installation for Ultimate transition couplers is the same as that for Ultimate standard couplers as described in Section 3.12 of this report.

3.14 nVent LENTON Ultimate Position Coupler (PT15, MS15, & MT12) (illustrated below):

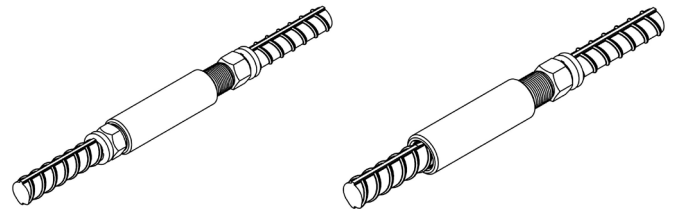

nVent LENTON Ultimate position coupler is used to connect curved or bent bars as well as straight bars that shall be held in a predetermined position during the connection process. Couplers may also be used where neither bar is free to rotate. Ultimate position couplers are manufactured to allow the coupler to rotate. The length adjustability of the Ultimate position coupler allows significant tolerance for bar gap and positioning during the connection process. The coupler consists of three components: coupler sleeve (PT15), male parallel thread (MS15), and male taper thread (MT12). The MS15 and MT12 components are attached to the connecting rebars by a friction forging process. Alternately, the MT12 component may be substituted by rebar with nVent LENTON tapered threads (illustration shown on the right). The connection is tightened per the manufacturer’s instructions. In addition, Ultimate position couplers are designed to accommodate rebars of different sizes.

3.15 nVent LENTON Connect Coupler (B12 & B22) (illustrated below):

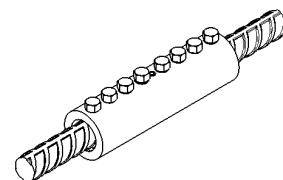

nVent LENTON Connect coupler is used to connect two rebars mechanically. One or both rebars are inserted into the coupler in a predetermined position and the bolts are tightened in accordance with the manufacturer’s instructions. As long as the torque values are achieved, the bolt heads are not required to shear off. Unsheared bolt heads may be cut off if concrete cover is an issue. Additional details are found in the manufacturer’s instructions. In addition to connecting two rebars of the same size, the Connect coupler may also be used to:

- Connect two rebars of the same size where both bars are one size smaller than the size identified on the coupler.
- Transition from one rebar of the bar size identified on the coupler to another rebar of the next smaller bar size.

3.16 nVent LENTON Connect Coupler (S2) (illustrated below):

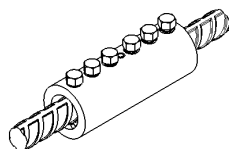

nVent LENTON Connect coupler is used to connect two rebars mechanically. One or both rebars are inserted into the coupler in a predetermined position and the bolts are tightened in accordance with the manufacturer’s instructions. As long as the torque values are achieved, the bolt heads are not required to shear off. Unsheared bolt heads may be cut off if concrete cover is an issue. Additional details are found in the manufacturer’s instructions. In addition to connecting two rebars of the same size, the Connect coupler may also be used to:

- Connect two rebars of the same size where both bars are one size smaller than the size identified on the coupler, and
- Transition from one rebar of the size identified on the coupler to another rebar of the next smaller bar size.

4.0 PRODUCT DESCRIPTION

4.1 General

nVent LENTON system consists of taper threaded rebar splicing and bolted rebar splicing and is designed for use in reinforced concrete construction. nVent LENTON taper threaded system utilizes a 6-degree tapered thread with a varying thread pitch of 1.25 mm, 2.0 mm, or 3.5 mm depending on the reinforcement size. nVent LENTON couplers are available in eleven styles: nVent LENTON Standard (A2 & A12), nVent LENTON Standard Transition (A2 & A12), nVent LENTON Form Saver (SA & FS), nVent LENTON Position (P9 & P8), nVent LENTON Lock (B1 & S1), nVent LENTON Interlok (LK), LENTON weldable half coupler (C2 & C3J), nVent LENTON Ultimate standard (FT12 & MT12), nVent LENTON Ultimate transition (FT12

& MT12), nVent LENTON Ultimate position (PT15, MS15, & MT12), and nVent LENTON Connect (B12, B22, & S2). nVent LENTON couplers are designed to mechanically butt splice No. 4, 0.5-inch-diameter (12 mm) through No. 18, 2.25-inch-diameter (57 mm) deformed reinforcing steel bars. All grades of rebar may be epoxy coated in accordance with ASTM A775 or A934 when utilizing nVent LENTON taper threaded or bolted couplers. In addition, all grades of rebar may be galvanized in accordance with ASTM A767 when utilizing nVent LENTON taper threaded connections. Coatings complying with ASTM A775, ASTM A934, and ASTM A767 shall be applied prior to rebar threading or in a manner as to not interfere with proper thread engagement.

All coupler styles, excluding the nVent LENTON Lock and Connect coupler types, have interior tapered threads for connecting the reinforcement. For the nVent LENTON threaded coupler types, threads on the rebar or attached components are right-handed and tapered to match the accompanying coupler. Before shipping from the rebar fabrication shop, threaded bar ends shall be protected.

4.2 Components

4.2.1 Couplers: The couplers’ descriptions and illustrations are listed in [Tables 1](#) to [20](#) of this report.

4.2.2 Grout:

4.2.2.1: nVent LENTON Interlok HY10L Grout: HY10L grout is a dry, cementitious material, packaged in 50-pound (22.7 kg) bags. Batches of grout shall be mixed in accordance with nVent installation instructions. The amount of water shall be 0.7 to 0.8 gallons (2.7 to 3.0 L) per bag. The correct amount of water to be added to the grout is predetermined by field-testing the flow of trial batches of grout mixtures with a 2-inch-diameter (51 mm), 4-inch-tall (102 mm) cylinder and an nVent LENTON Interlok flow template to obtain a flow of 5 to 6 inches (127 to 152 mm). Where flows exceed 6½ inches (165 mm), the trial batch shall be discarded, and a new trial batch shall be prepared. The minimum compressive strength shall be 8,500 psi (58.6 MPa) at 28 days. Compressive strength tests shall be conducted in accordance with ASTM C942 on 2-inch (51 mm) cube specimens cured at 70°F (21°C). The shelf life of nVent LENTON Interlok HY10L Grout is 12 months from the manufacturing date printed on the bag when stored indoors in a cool, dry environment.

4.2.2.2 nVent LENTON Interlok HY15LM Grout: HY15LM grout is a dry, cementitious material, packaged in 50-pound (22.7 kg) bags. Batches of grout shall be mixed in accordance with nVent installation instructions. The amount of water shall be 0.7 to 0.78 gallons (2.7 to 2.95 L) per bag. For optimum pumping conditions, the correct amount of water to be added to the grout is predetermined by field-testing the flow of trial batches of grout mixtures with a 2-inch-diameter (51 mm), 4-inch-tall (102 mm) cylinder and an Interlok flow template. For ease of pumping, the desired



flow is 7 to 12 inches (178 to 305 mm). The minimum compressive strength shall be 7,500 psi (51.7 MPa) for Grade 60 bars or 9,000 psi (62 MPa) for Grade 75 and 80 bars at 28 days. Compressive strength tests shall be conducted in accordance with ASTM C942 on 2-inch (51 mm) cube specimens cured at 70°F (21°C). The shelf life of Interlok HY15LM Grout is 12 months from the manufacturing date printed on the bag when stored indoors in a cool, dry environment.

5.0 IDENTIFICATION

All couplers and splices are packaged with a label bearing the manufacturer's name (ERICO International Corporation) or brand name (nVent LENTON), address, model and size, and the Evaluation Report Number (ER-0129) to identify the products recognized in this report. Each nVent LENTON coupler is permanently stamped/labeled with the catalog number, size, heat number, Type 2 designation (except nVent LENTON Lock S1 and nVent LENTON Connect S2), and the name "LENTON." Either IAPMO UES Mark of Conformity may also be used as shown below:

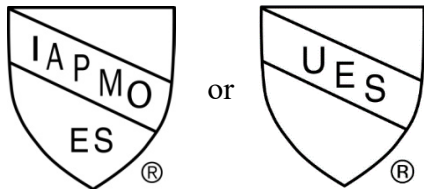

IAPMO UES ER-0129

6.0 EVIDENCE SUBMITTED

6.1 Data submitted in accordance with the Acceptance Criteria for Mechanical Connector Systems for Steel Reinforcing Bars (ICC-ES AC133).

6.2 Test reports are from laboratories in compliance with ISO/IEC 17025.

7.0 STATEMENT OF RECOGNITION:

This report describes the results of research completed by the IAPMO Uniform Evaluation Service on nVent LENTON Mechanical Splice System for Steel Reinforcing Bars in Concrete to assess its conformance to the codes listed in Section 1.0 and serves as documentation of the product certification. The products are manufactured at the location noted in Section 2.17 of this report under a quality control program with periodic inspections under the supervision of IAPMO UES.

For additional information about this evaluation report please visit www.uniform-es.org or email at info@uniform-es.org



Table 1: nVent LENTON System Specification

Series	Part Number Suffix	Material Grade	Rebar Grades	Rebar Sizes	Code Compliance	Section
nVent LENTON Standard Coupler	A2, A12	American Iron and Steel Institute (AISI) 1117/1141 (or equivalent)	ASTM® A706 Grades 60 and 80; A615 Grades 60, 75, and 80	No. 4 through 18	IBC®, IRC® TYPE I + II	3.4
nVent LENTON Standard Transition Coupler	A2, A12	AISI 1117/1141 (or equivalent)	ASTM A706 Grades 60 and 80; A615 Grades 60, 75, and 80	No.4 through 18	IBC, IRC TYPE I + II	3.5
nVent LENTON FORM SAVER	SA	AISI 1117/1141 (or equivalent)	ASTM A706 Grades 60 and 80; A615 Grades 60, 75, and 80	No.4 through 11	IBC, IRC TYPE I + II	3.6
	FS	AISI 1117 (or equivalent)	ASTM A706 Grade 60; A615 Grades 60 and 75	No.4 through 7	IBC, IRC TYPE I + II	3.6
nVent LENTON Position Coupler	P9, P8	AISI 1141 (or equivalent)	ASTM A706 Grades 60 and 80; A615 Grades 60, 75, and 80	No.5 through 18	IBC, IRC TYPE I + II	3.7
nVent LENTON Lock	B1	AISI 4118/4120 (or equivalent)	ASTM A706 Grade 60; A615 Grades 60 and 75	No.4 through 18	IBC, IRC TYPE I + II	3.8
	S1	AISI 4118/4120 (or equivalent)	ASTM A706 Grade 60	No.4 through 18	IBC, IRC TYPE I + II	3.9
	S1	AISI 4118/4120 (or equivalent)	ASTM A615 Grade 60	No.4 through 18	IBC, IRC TYPE I	3.9
nVent LENTON Interlok	LK with HY10L	ASTM A536 (or equivalent)	ASTM A706 Grade 60; A615 Grade 60	No.6 through 14	IBC, IRC TYPE I + II	3.10
	LK with HY15LM	ASTM A536 (or equivalent)	ASTM A706 Grades 60 and 80; A615 Grades 60, 75, and 80	No.5 through 18	IBC, IRC TYPE I + II	3.10
nVent LENTON Weldable Half Coupler	C2, C3J	AISI 1018/1030/1035 (or equivalent)	ASTM A706 Grades 60 and 80; A615 Grades 60, 75, and 80	No.4 through 18	IBC, IRC TYPE I + II	3.11
nVent LENTON Ultimate Standard Coupler	FT12, MT12 ¹	AISI 1045 (or equivalent)	ASTM A706 Grades 60 and 80; A615 Grades 60, 75, and 80	No.4 through 18	IBC, IRC TYPE I + II	3.12
nVent LENTON Ultimate Transition Coupler	FT12, MT12 ¹	AISI 1045 (or equivalent)	ASTM A706 Grades 60 and 80; A615 Grades 60, 75, and 80	No.4 through 18	IBC, IRC TYPE I + II	3.13



Table 1: nVent LENTON System Specification (Continued)

Series	Part Number Suffix	Material Grade	Rebar Grades	Rebar Sizes	Code Compliance	Section
nVent LENTON Ultimate Position Coupler	PT15, MS15, MT12 ¹	AISI 1045 (or equivalent)	ASTM A706 Grades 60 and 80; A615 Grades 60, 75, and 80	No.4 through 18	IBC, IRC TYPE I + II	3.14
nVent LENTON Connect	B12	AISI 1030/1035 (or equivalent)	ASTM A706 Grade 60; A615 Grade 60	No.4 through 11	IBC, IRC TYPE I + II	3.15
	B22	AISI 1033 (or equivalent)	ASTM A706 Grades 60 and 80; A615 Grades 60, 75, and 80	No.4 through 11	IBC, IRC TYPE I + II ²	3.15
	S2	AISI 1030/1033/1035 (or equivalent)	ASTM A706 Grade 60	No.4 through 11	IBC, IRC TYPE I + II	3.16
	S2	AISI 1030/1033/1035 (or equivalent)	ASTM A615 Grade 60	No.4 through 11	IBC, IRC TYPE I	3.16

Notes:

1. MT12 component may be substituted with nVent LENTON taper threaded rebar for IBC, IRC Type I + II.
2. B22 is compliant as a Type 2HS Splice for No. 4 through 7 Rebar Sizes.

nVent LENTON Standard Couplers - A2/A12 Series

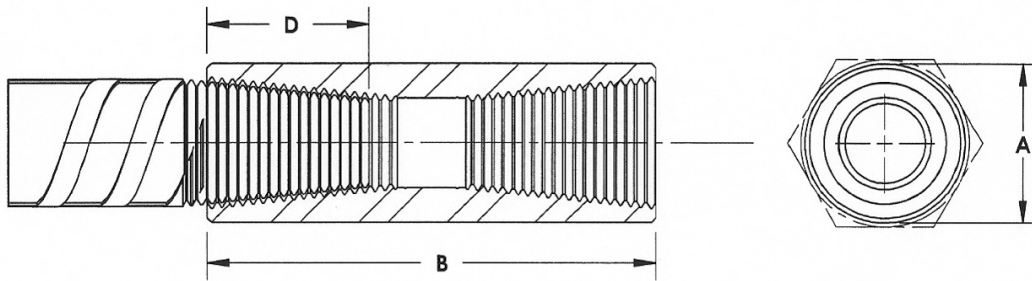

A = Diameter
 B = Length of Coupler
 D = Bar Engagement

Table 2: nVent LENTON Standard Couplers – A2 Series

Reinforcement Bar Designation				Part Number	"A"		"B"		"D"	
No.	Metric (mm)	Canadian	Soft Metric		in	mm	in	mm	in	mm
4	12	10M	13	EL12A2*	11/16	17	1-5/8	41	9/16	14
5	16	15M	16	EL16A2*	7/8	22	2-3/16	56	7/8	22
6	20	20M	19	EL20A2*	1-1/16	27	2-13/16	71	1-1/8	29
7	22	–	22	EL22A2*	1-3/16	30	3-5/32	80	1-1/4	32
8	25	25M	25	EL25A2	1-3/8	35	3-11/32	85	1-3/8	35
9	28	30M	29	EL28A2	1-1/2	38	3-19/32	91	1-1/2	38
10	32	–	32	EL32A2	1-3/4	44	3-25/32	96	1-9/16	40
11	36	35M	36	EL36A2	1-7/8	48	3-31/32	101	1-11/16	43
–	38	–	38	EL38A2	2	51	4-1/8	105	1-3/4	44
–	40	–	–	EL40A2	2-3/16	52	4-15/16	125	2-3/16	56
14	43	45M	43	EL43TA2	2-1/4	57	5-1/4	133	2-1/8	56
–	50	–	–	EL50TA2	2-9/16	64	6-13/32	163	2-3/4	70
18	57	55M	57	EL57TA2	3	76	6-1/2	164	2-3/4	71

*Uses hexagonal material (measured across the flats); others use round material.



Table 3: nVent LENTON Standard Couplers – A12 Series

Reinforcement Bar Designation		Part Number	“A” mm	“B” mm	“D” mm
No.	Metric (mm)				
–	10	EL10A12*	17	48	18
4	12	EL12A12*	17	49	18
–	14	EL14A12*	22	55	21
5	16	EL16A12*	22	61	24
–	18	EL18A12*	27	71	29
6	20	EL20A12*	27	88	36
7	22	EL22A12*	33	91	38
8	25	EL25A12	33	96	41
9	28	EL28A12	37	101	43
–	30	EL30A12	37	121	53
10	32	EL32A12	42	107	46
–	34	EL34A12	41	128	56
11	36	EL36A12	46	121	53
–	38	EL38A12	52	124	54
–	40	EL40A12	52	131	58
14	43	EL43TA12	58	155	68
–	50	EL50TA12	64	163	71
18	57	EL57TA12	75	189	84

*Uses hexagonal material (measured across the flats); others use round material.



nVent LENTON Standard Transition Couplers - A2/A12 Series

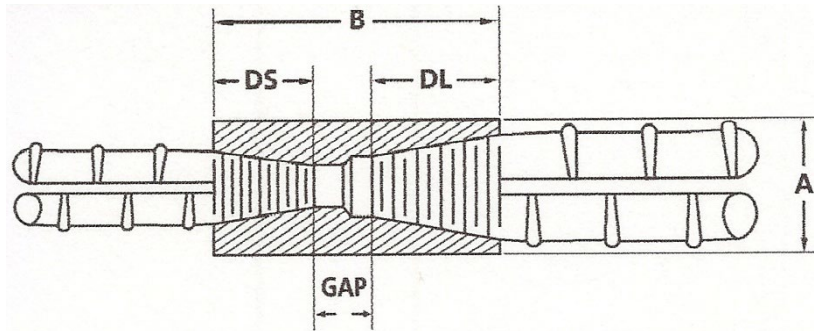

A = Diameter
 B = Length of Coupler
 DL = Large Bar Engagement
 DS = Small Bar Engagement

Table 4: nVent LENTON Standard Transition Couplers – A2 Series

Reinforcement Bar Designation		Part Number	"A" in	"B" in	"DL" in	"DS" in
No.	Metric (mm)					
4 to 5	12 to 16	EL1612A2*	7/8	2-5/16	7/8	9/16
5 to 6	16 to 20	EL2016A2*	1-1/16	3	1-1/8	7/8
6 to 7	20 to 22	EL2220A2*	1-3/16	3-13/32	1-1/4	1-1/8
7 to 8	22 to 25	EL2522A2	1-3/8	3-11/16	1-3/8	1-1/4
8 to 9	25 to 28	EL2825A2	1-1/2	3-29/32	1-1/2	1-3/8
9 to 10	28 to 32	EL3228A2	1-3/4	4-1/8	1-9/16	1-1/2
10 to 11	32 to 36	EL3632A2	1-7/8	4-5/16	1-11/16	1-9/16
11 to 14	36 to 43	EL43T36A2	2-1/4	4-21/32	2-1/8	1-11/16
11 to 18	36 to 57	EL57T36A2	3	5-11/16	2-3/4	1-11/16
14 to 18	43 to 57	EL57T43TA2	3	6-5/16	2-3/4	2-1/8

*Uses hexagonal material (measured across the flats); others use round material.



Table 5: nVent LENTON Standard Transition Couplers – A12 Series

Reinforcement Bar Designation		Part Number	"A" in	"B" in	"DL" in	"DS" in
No.	Metric (mm)					
4 to 5	12 to 16	EL1612A12*	7/8	2-13/32	15/16	3/4
5 to 6	16 to 20	EL2016A12*	1-1/16	3-5/32	1-3/8	15/16
6 to 7	20 to 22	EL2220A12*	1-3/16	3-3/4	1-7/16	1-3/8
7 to 8	22 to 25	EL2522A12	1-3/8	3-15/16	1-9/16	1-7/16
8 to 9	25 to 28	EL2825A12	1-1/2	4-1/8	1-5/8	1-9/16
9 to 10	28 to 32	EL3228A12	1-3/4	4-11/32	1-3/4	1-5/8
10 to 11	32 to 36	EL3632A12	1-7/8	4-23/32	2-1/16	1-3/4
11 to 14	36 to 43	EL43T36A12	2-1/4	5-13/16	2-5/8	2-1/16
11 to 18	36 to 57	EL57T36A12	3	6-9/16	3-1/8	2-1/16
14 to 18	43 to 57	EL57T43TA12	3	7-1/4	3-1/8	2-5/8

*Uses hexagonal material (measured across the flats); others use round material.



nVent LENTON Form Saver Couplers – SA Series

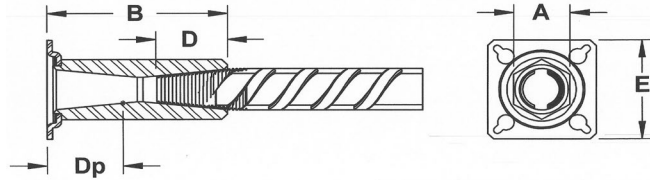

- A = Diameter
- B = Length of Coupler Body
- D = Bar Engagement Non-Mounting Plate Side
- Dp = Bar Engagement Mounting Plate Side
- E = Length of Mounting Plate

Table 6: nVent LENTON Form Saver Couplers – SA Series

Reinforcement Bar Designation		Part No.	"A"		"B"		"D"		"Dp"		"E"	
No.	Metric (mm)		in	mm	in	mm	in	mm	in	mm	in	mm
4	12	EL12SA*	11/16	17	1-15/16	49	9/16	14	7/8	22	2-1/4	57
5	16	EL16SA*	7/8	22	2-1/2	64	7/8	22	1-3/16	30	2-1/4	57
6	20	EL20SA*	1-1/16	27	3-1/8	79	1-1/8	29	1-7/16	37	2-1/4	57
7	22	EL22SA*	1-3/16	30	3-15/32	88	1-1/4	32	1-9/16	40	2-1/4	57
8	25	EL25SA	1-3/8	35	3-21/32	93	1-3/8	35	1-11/16	43	2-1/4	57
9	28	EL28SA	1-1/2	38	3-29/32	99	1-1/2	38	1-13/16	46	2-1/2	63
10	32	EL32SA	1-3/4	44	4-3/32	104	1-9/16	40	1-7/8	48	2-1/2	63
11	36	EL36SA	1-7/8	48	4-9/32	109	1-11/16	43	2	51	2-1/2	63

*Uses hexagonal material (measured across the flats); others use round material.



nVent LENTON Form Saver Couplers – FS Series

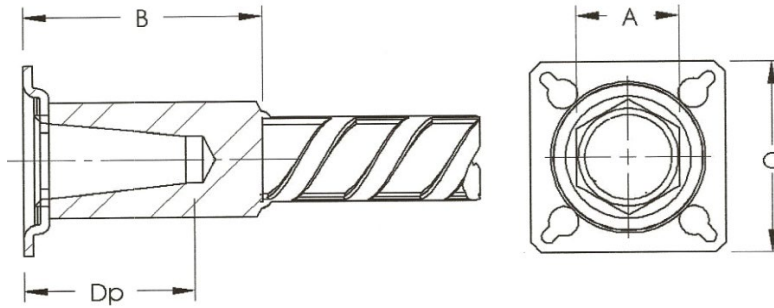

A = Diameter
 B = Length of Coupler
 C = Length and Width of Mounting Plate
 Dp = Bar Engagement

Table 7: nVent LENTON Form Saver Couplers – FS Series

Reinforcement Bar Designation		Part No.	"A"		"B"		"C"		"Dp"	
No.	Metric (mm)		in	mm	in	mm	in	mm	in	mm
4	12	ELC12FS2*	7/8	22	1-13/16	46	2-1/4	57	7/8	22
5	16	ELC16FS2*	7/8	22	2-1/16	52	2-1/4	57	1-3/16	30
6	20	ELC20FS2*	1-1/16	27	2-9/16	65	2-1/4	57	1-7/16	36
7	22	ELC22FS2*	1-3/16	30	2-13/16	71	2-1/4	57	1-9/16	39

*Uses hexagonal material (measured across the flats); others use round material.



nVent LENTON Position Couplers – P9 Series

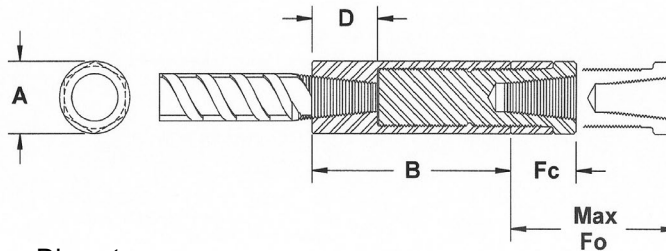

A = Diameter
 B = Length of Coupler Body
 D = Bar Engagement
 Fc = Connector Closed Position
 Max. Fo = Connector Fully Open Position

Table 8: nVent LENTON Position Couplers – P9 Series

Reinforcement Bar Designation		Part No.	"A"		"B"		"D"		"Fc"		"Max. Fo"	
No.	Metric (mm)		in	mm	in	mm	in	mm	in	mm	in	mm
6	20	EL20P9	1-13/16	46	2-3/4	70	1-1/8	29	1-5/8	41	2-1/8	54
7	22	EL22P9	1-13/16	46	3-1/16	78	1-1/4	32	1-5/8	41	2-1/8	54
8	25	EL25P9	1-13/16	46	3-3/8	86	1-3/8	35	1-5/8	41	2-1/8	54
9	28	EL28P9	2-1/2	64	3-9/16	90	1-1/2	38	1-5/8	41	2-1/8	54
10	32	EL32P9	2-1/2	64	3-13/16	97	1-9/16	40	1-5/8	41	2-1/8	54
11	36	EL36P9	2-1/2	64	4-3/16	98	1-11/16	43	1-5/8	41	2-1/8	54
14	43	EL43TP9	3	76	5	127	2-1/8	54	3-13/16	97	4-5/8	117
18	57	EL57TP9	4	95	6-1/8	156	2-3/4	70	4-3/8	111	5-13/16	148



nVent LENTON Position Couplers – P8 Series

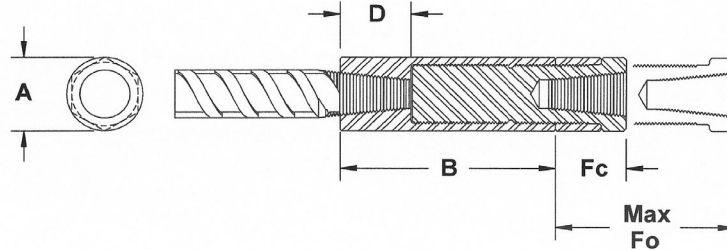

A = Diameter
 B = Length of Coupler Body
 D = Bar Engagement
 Fc = Connector Closed Position
 Max. Fo = Connector Fully Open Position

Table 9: nVent LENTON Position Couplers – P8 Series

Reinforcement Bar Designation		Part No.	"A"		"B"		"D"		"Fc"		"Max. Fo"	
No.	Metric (mm)		in	mm	in	mm	in	mm	in	mm	in	mm
5	16	EL16P8	1-13/16	46	4-7/16	113	7/8	22	1-1/2	38	2-9/16	65
6	20	EL20P8	1-13/16	46	4-7/16	113	1-1/8	29	1-9/16	39	2-9/16	65
7	22	EL22P8	1-13/16	46	4-15/16	125	1-1/4	32	1-1/2	38	2-3/4	70
8	25	EL25P8	1-13/16	46	5-5/16	135	1-3/8	35	1-1/2	38	2-13/16	72
9	28	EL28P8	2-1/2	64	5-5/8	143	1-1/2	38	1-1/2	38	2-15/16	75
10	32	EL32P8	2-1/2	64	6	152	1-9/16	40	1-1/2	38	3-1/16	78
11	36	EL36P8	2-1/2	64	6-7/16	164	1-11/16	43	1-9/16	39	3-3/8	85
14	43	EL43TP8	3	76	7-13/16	198	2-1/8	54	3-19/32	92	7-5/16	186
18	57	EL57TP8	4	95	9-17/32	242	2-3/4	70	4-5/32	106	8-15/32	215



nVent LENTON Lock Couplers – B1 Series

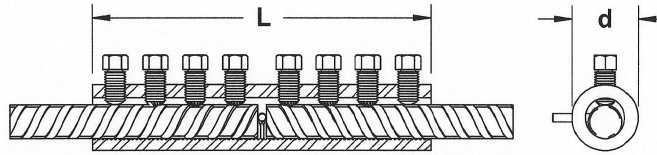

L = Coupler Length
d = Outside Diameter

Table 10: nVent LENTON Lock Couplers – B1 Series

Reinforcement Bar Designation		Part No	"L" Length		"d" Outside Diameter		Inside Diameter		Number of Bolts
No.	Metric (mm)		in	mm	in	mm	in	mm	
–	10	LL12B1	5	127	1.1	29	0.6	15	6
4	12	LL12B1	5	127	1.1	29	0.6	15	6
–	14	LL16B1	6.3	159	1.4	35	0.7	19	6
5	16	LL16B1	6.3	159	1.4	35	0.7	19	6
–	18	LL20B1	7.5	191	1.7	44	0.9	24	8
6	20	LL20B1	7.5	191	1.7	44	0.9	24	8
7	22	LL22B1	8.7	222	1.9	48	1.1	28	8
8	25	LL25B1	10	254	2.1	54	1.2	30	8
9	28	LL28B1	11.3	287	2.4	60	1.3	34	10
–	30	LL28B1	11.3	287	2.4	60	1.3	34	10
10	32	LL32B1	12.7	323	2.6	65	1.5	38	8
–	34	LL36B1	14.1	358	2.8	72	1.7	43	10
11	36	LL36B1	14.1	358	2.8	72	1.7	43	10
–	38	LL40B1	15.7	400	3.1	80	1.9	47	12
–	40	LL40B1	15.7	400	3.1	80	1.9	47	12
14	43	LL43B1	20.6	523	3.5	89	2.1	53	14
--	50	LL50B1	23.3	593	4.0	102	2.4	60	16
18	57	LL57B1	26.1	662	4.5	117	2.6	67	18



nVent LENTON Lock Couplers – S1 Series

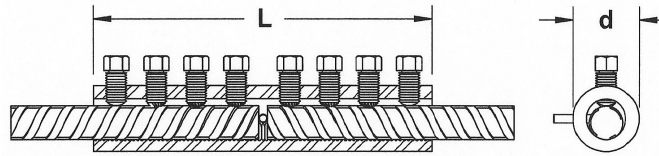

L = Coupler Length
d = Outside Diameter

Table 11: nVent LENTON Lock Couplers – S1 Series

Reinforcement Bar Designation		Part No	“L” Length		“d” Outside Diameter		Inside Diameter		Number of Bolts
No.	Metric (mm)		in	mm	In	mm	in	mm	
–	10	LL12S1	3.9	99	1.1	29	0.6	15	4
4	12	LL12S1	3.9	99	1.1	29	0.6	15	4
–	14	LL16S1	4.3	109	1.4	35	0.7	19	4
5	16	LL16S1	4.3	109	1.4	35	0.7	19	4
–	18	LL20S1	6.0	153	1.7	44	0.9	24	6
6	20	LL20S1	6.0	153	1.7	44	0,9	24	6
7	22	LL22S1	6.8	173	1.9	48	1.1	28	6
8	25	LL25S1	6.8	173	2.1	54	1.2	30	6
9	28	LL28S1	6.8	173	2.4	60	1.3	34	6
–	30	LL28S1	6.8	173	2.4	60	1.3	34	6
10	32	LL32S1	8.7	220	2.6	65	1.5	38	6
–	34	LL36S1	11.3	286	2.8	72	1.7	43	8
11	36	LL36S1	11.3	286	2.8	72	1.7	43	8
–	38	LL40S1	13.9	352	3.1	80	1.9	47	10
–	40	LL40S1	13.9	352	3.1	80	1.9	47	10
14	43	LL43S1	16.5	418	3.5	89	2.1	53	12
–	50	LL57S1	22.5	572	4.5	114	2.6	67	14
18	57	LL57S1	22.5	572	4.5	114	2.6	67	14



nVent LENTON Interlok Couplers – LK Series

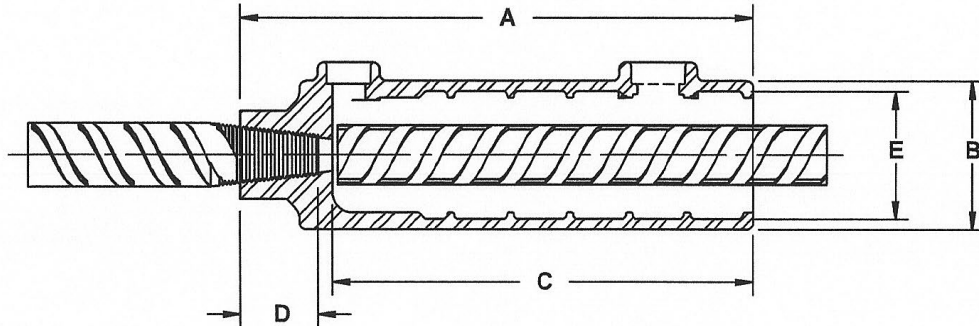

- A = Length
- B = Outside Diameter
- C = Grouted Max. Bar Embedment
- D = Threaded Bar Engagement
- E = Inside Diameter

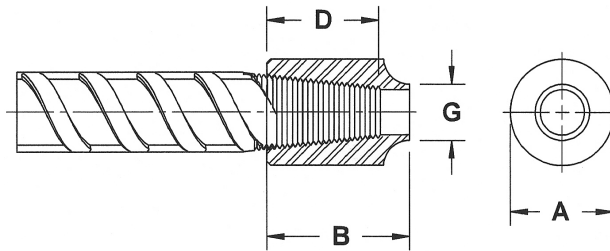

Table 12: nVent LENTON Interlok Couplers – LK Series

Reinforcement Bar Designation		Part No.	"A"		"B"		"C"		"D"		"E"	
No.	Metric (mm)		in	mm	in	mm	in	mm	in	mm	in	mm
5	16	LK5	7.81	198.4	2.56	65.1	6.13	155.5	0.86	21.8	2.13	54
5	16	LK16	7.91	200.9	2.31	58.7	6.62	168.2	1.190	30.22	1.88	47.6
6	20	LK6	7-5/8	195	2-7/16	62	6-1/8	156	1-1/8	29	1-7/8	48
6	20	LK20	8.79	223.3	2.44	61.9	7.0	177.8	1.691	42.95	2.0	50.8
7	22	LK7	7-5/8	195	2-7/16	62	6-1/8	156	1-1/4	32	1-7/8	48
7	22	LK22	8.89	225.8	2.56	65.1	7.01	178	1.784	45.32	2.13	54
8	25	LK8	8-5/8	219	2-5/8	67	7	178	1-3/8	35	2	51
8	25	LK25	8.98	228.1	2.69	68.3	7	177.8	1.884	47.86	2.25	57.2
9	28	LK9	9-3/4	248	2-3/4	70	8	203	1-1/2	38	2-1/8	54
9	28	LK28	10.07	255.8	2.81	71.4	8	203.2	1.970	50.04	2.38	60.3
10	32	LK10	10-13/16	275	2-15/16	75	9	229	1-9/16	40	2-5/16	59
10	32	LK32	11.2	284.5	3.0	76.2	9	228.6	2.100	53.34	2.56	65.1
11	36	LK11	12	295	3-1/8	79	9-7/8	251	1-11/16	43	2-7/16	62
11	36	LK36	12.34	313.4	3.19	81.0	9.88	251	2.364	53	2.69	68.3
-	40	LK40	15	381	3-11/16	94	12-3/4	324	2-1/8	56	2-3/4	70
14	43	LKT14	15	381	3-11/16	94	12-3/4	324	2-1/8	54	2-3/4	70
14	43	LKT43	15.94	404.9	3.69	93.7	12.75	323.8	3.093	60.03	3.06	77.8
-	50	LKT50	20-5/16	508	4-1/2	114	17	432	2-3/4	71	3-1/4	83
18	57	LKT18	20-5/16	508	4-1/2	114	17	432	2-3/4	72	3-1/4	83
18	57	LKT57	20.87	530.1	4.5	114.3	17	432	3.767	95.69	3.56	90.5



nVent LENTON Weldable Half Couplers – C2 and C3J Series



A = Coupler Diameter
 B = Length of Coupler
 D = Bar Engagement
 G = Small Diameter

Table 13: nVent LENTON Weldable Half Couplers – C2 and C3J Series

Reinforcement Bar Designation		Part No.	"A"		"B"		"D"		"G"	
No.	Metric (mm)		in	mm	in	mm	in	mm	in	mm
4	12	EL12C2	0.79	20	1.19	30	0.58	15	0.44	11
5	16	EL16C2	0.98	25	1.38	35	0.86	22	0.56	14
6	20	EL20C3J	1.25	32	2.16	55	1.09	28	0.88	22
7	22	EL22C3J	1.25	32	2.41	61	1.26	32	0.75	19
8	25	EL25C3J	1.56	40	2.53	64	1.36	34	1.00	25
9	28	EL28C3J	1.56	40	2.69	68	1.49	38	0.94	24
10	32	EL32C3J	2.00	51	2.88	73	1.58	40	0.94	24
11	36	EL36C3J	2.00	51	2.97	75	1.68	43	1.13	29
14	43	EL43TC3J	2.38	60	3.75	95	2.20	56	1.41	36
18	57	EL57TC3J	3.13	80	4.50	114	2.81	71	1.75	44



nVent LENTON Ultimate Standard Couplers – FT12 Series

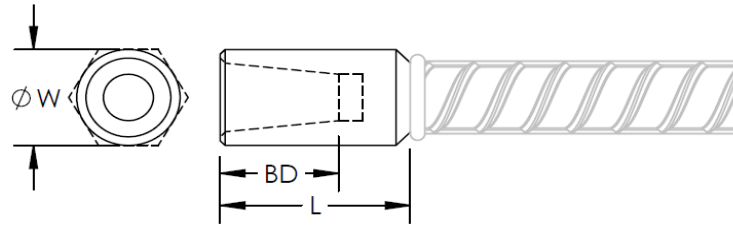

W = Coupler Diameter
 L = Length of Coupler
 BD = Bar Engagement

Table 14: nVent LENTON Ultimate Standard Couplers – FT12 Series

Reinforcement Bar Designation		Part No.	"W" Hex		"W" Round		"L"		"BD"	
No.	Metric (mm)		in	mm	in	mm	in	mm	in	mm
4	12	LU12FT12	0.69	17	----	----	1.54	39	0.84	21
5	16	LU16FT12	0.88	22	----	----	1.82	46	1.06	27
6	20	LU20FT12	1.06	27	----	----	2.48	63	1.54	39
7	22	LU22FT12	1.19	30	----	----	2.60	66	1.63	41
8	25	LU25FT12	----	----	1.38	35	2.77	70	1.73	44
9	28	LU28FT12	----	----	1.50	38	2.87	73	1.82	46
10	32	LU32FT12	----	----	1.75	44	3.04	77	1.95	50
11	36	LU36FT12	----	----	1.88	48	3.37	86	2.21	56
14	43	LU43TFT12	----	----	2.25	57	4.39	112	2.90	74
18	57	LU57TFT12	----	----	3.00	76	5.23	133	3.57	91



nVent LENTON Ultimate Standard, Transition, and Position Couplers – MT12 Series

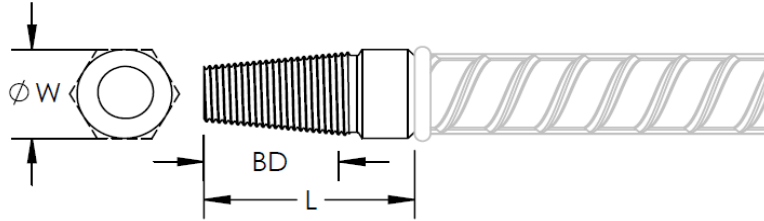

W = Diameter
 L = Length of Coupler
 BD = Bar Engagement

Table 15: nVent LENTON Ultimate Standard, Transition, and Position Couplers – MT12 Series

Reinforcement Bar Designation		Part No.	"W" Hex		"W" Round		"L"		"BD"	
No.	Metric (mm)		in	mm	in	mm	in	mm	in	mm
4	12	LU12MT12	0.69	17	----	----	1.66	42	0.84	21
5	16	LU16MT12	0.88	22	----	----	1.89	48	1.06	27
6	20	LU20MT12	1.06	27	----	----	2.41	61	1.54	39
7	22	LU22MT12	1.06	27	----	----	2.66	68	1.63	41
8	25	LU25MT12	1.19	30	----	----	2.80	71	1.73	44
9	28	LU28MT12	----	----	1.38	35	2.88	73	1.82	46
10	32	LU32MT12	----	----	1.50	38	3.21	82	1.95	50
11	36	LU36MT12	----	----	1.75	44	3.47	88	2.21	56
14	43	LU43TMT12	----	----	2.00	51	4.48	114	2.90	74
18	57	LU57TMT12	----	----	2.50	64	5.40	137	3.57	91



nVent LENTON Ultimate Transition Couplers – FT12 Series

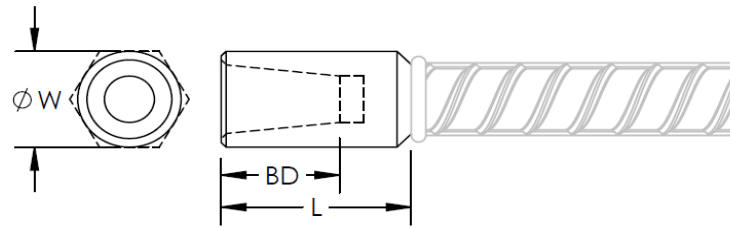

W = Coupler Diameter
 L = Length of Coupler
 BD = Small Bar Engagement

Table 16: nVent LENTON Ultimate Transition Couplers – FT12 Series

Reinforcement Bar Designation		Part No.	"W" Hex		"W" Round		"L"		"BD"	
No.	Metric (mm)		in	mm	in	mm	in	mm	in	mm
4 to 5	12 to 16	LU1612FT12	7/8	22	----	----	1-13/16	46	3/4	19
5 to 6	16 to 20	LU2016FT12	1-1/16	27	----	----	2-15/32	63	1	25
6 to 7	20 to 22	LU2220FT12	1-3/16	30	----	----	2-19/32	66	1-7/16	36
7 to 8	22 to 25	LU2522FT12	----	----	1-3/8	35	2-3/4	70	1-1/2	39
8 to 9	25 to 28	LU2825FT12	----	----	1-1/2	38	2-7/8	73	1-5/8	41
9 to 10	28 to 32	LU3228FT12	----	----	1-3/4	44	3-1/16	77	1-11/16	43
10 to 11	32 to 36	LU3632FT12	----	----	1-7/8	48	3-3/8	86	1-27/32	47
11 to 14	36 to 43	LU4336FT12	----	----	2-1/4	57	4-3/8	112	2-3/32	53
11 to 18	36 to 57	LU5736FT12	----	----	3	76	5-1/4	133	2-3/32	53
14 to 18	43 to 57	LU5743TFT12	----	----	3	76	5-1/4	133	2-11/16	69



nVent LENTON Ultimate Position Couplers – PT15, MS15 Series

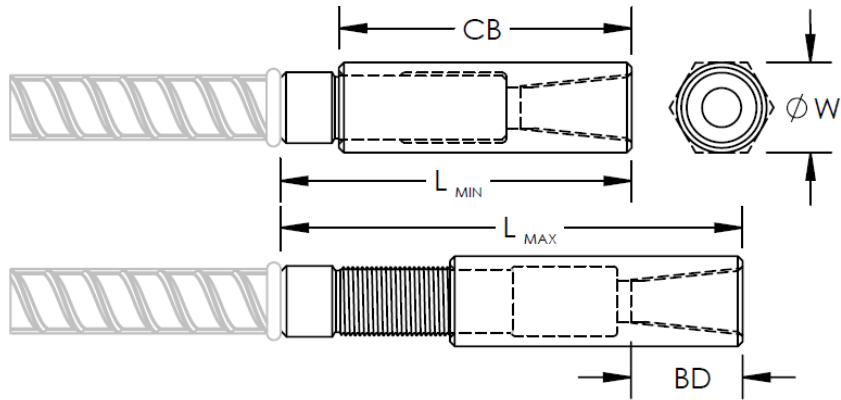

- W = Diameter
- CB = Length of Coupler Body
- BD = Bar Engagement
- L_{MIN} = Minimum Length Closed Position
- L_{MAX} = Maximum Length Fully Open Position

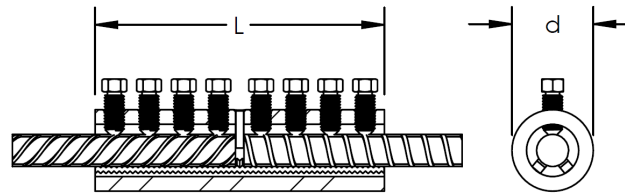

Table 17: nVent LENTON Ultimate Position Couplers – PT15, MS15 Series

Reinforcement Bar Designation		Part No.	"W" Hex		"W" Round		"CB"		"BD"		"L _{MIN} "		"L _{MAX} "	
No.	Metric (mm)		in	mm	in	mm	in	mm	in	mm	in	mm	in	mm
4	12	LU12PT15 LU12MS15	7/8	22	----	----	2- 17/32	64	3/4	19	3-1/4	82	4-3/16	106
5	16	LU16PT15 LU16MS15	1-1/16	27	----	----	3-3/32	79	1	25	4	102	5-3/16	132
6	20	LU20PT15 LU20MS15	----	----	1-3/8	35	4- 11/32	110	1-7/16	36	5-1/4	133	6- 31/32	177
7	22	LU22PT15 LU22MS15	----	----	1-3/8	35	4- 19/32	116	1-1/2	39	5-1/2	139	7-5/16	186
8	25	LU25PT15 LU25MS15	----	----	1-1/2	38	4-7/8	124	1-5/8	41	6	153	7- 15/16	201
9	28	LU28PT15 LU28MS15	----	----	1-3/4	45	5-1/8	131	1- 11/16	43	6-1/2	165	8- 15/32	215
10	32	LU32PT15 LU32MS15	----	----	2	51	5- 17/32	140	1- 27/32	47	6-7/8	174	9	228
11	36	LU36PT15 LU36MS15	----	----	2-1/4	57	6-3/16	157	2-3/32	53	7-1/2	191	9- 29/32	252
14	43	LU43TPT15 LU43TMS15	----	----	2-3/4	70	8-1/16	205	2- 11/16	69	9- 27/32	250	13- 1/16	332
18	57	LU57TPT15 LU57TMS15	----	----	4	102	10- 5/16	262	3-3/8	86	12-1/2	317	16-3/8	416



nVent LENTON Connect Couplers – B12 Series



L = Coupler Length
d = Outside Diameter

Table 18: nVent LENTON Connect Couplers – B12 Series

Reinforcement Bar Designation		Part No.	“L” Length		“d” Outside Diameter		Number of Bolts
No.	Metric (mm)		in	mm	in	mm	
4	12	LC16B12	5.1	131	1.63	41.4	6
5	16	LC16B12	5.1	131	1.63	41.4	6
6	20	LC20B12	6.8	172	1.90	48.3	8
7	22	LC22B12	8.7	220	2.00	50.8	10
8	25	LC25B12	10.7	272	2.38	60.5	10
9	28	LC28B12	11.2	284	2.80	71.1	8
10	32	LC32B12	13.7	348	3.00	76.2	10
11	36	LC36B12	16.2	411	3.13	79.5	12



nVent LENTON Connect Couplers – S2 Series

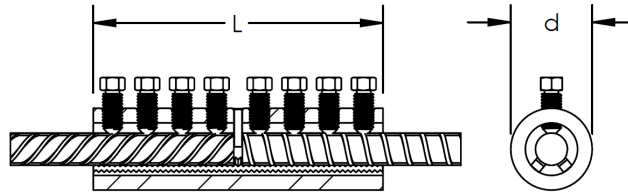

L = Coupler Length
 d = Outside Diameter

Table 19: nVent LENTON Connect Couplers – S2 Series

Reinforcement Bar Designation		Part No	"L" Length		"d" Outside Diameter		Number of Bolts
No.	Metric (mm)		in	mm	in	mm	
4	12	LC16S2	3.5	89	1.63	41.4	4
5	16	LC16S2	3.5	89	1.63	41.4	4
6	20	LC20S2	5.1	131	1.90	48.3	6
7	22	LC22S2	6.9	174	2.00	50.8	8
8	25	LC25S2	8.7	221	2.38	60.5	8
9	28	LC28S2	8.7	221	2.80	71.1	6
10	32	LC32S2	11.2	284	3.00	76.2	8
11	36	LC36S2	13.7	348	3.13	79.5	10



nVent LENTON Connect Couplers – B22 Series

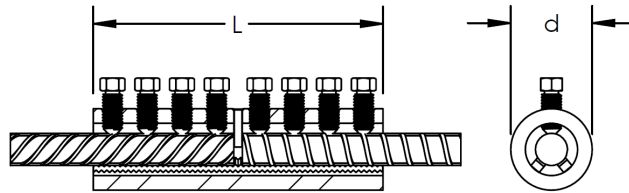

L = Coupler Length
d = Outside Diameter

Table 20: nVent LENTON Connect Couplers – B22 Series

Reinforcement Bar Designation		Part No	“L” Length		“d” Outside Diameter		Number of Bolts
No.	Metric (mm)		in	mm	in	mm	
4	12	LC16B22	7.3	185	1.63	41.4	8
5	16	LC16B22	7.3	185	1.63	41.4	8
6	20	LC20B22	10.5	267	1.90	48.3	12
7	22	LC22B22	14.3	363	2.00	50.8	16
8	25	LC25B22	15.6	396	2.38	60.5	14
9	28	LC28B22	17.2	437	2.80	71.1	12
10	32	LC32B22	19.7	500	3.00	76.2	14
11	36	LC36B22	22.2	564	3.13	79.5	16



CITY OF LOS ANGELES SUPPLEMENT

ERICO INTERNATIONAL CORPORATION

34600 Solon Road
Solon, Ohio 44139
800 248-2677

www.erico.com
michael.ugalde@nvent.com
michael.kolta@nvent.com
ward.judson@nvent.com

nVent LENTON Mechanical Splice System for Steel Reinforcing Bars in Concrete

CSI Section:
03 21 00 Reinforcing Steel

1.0 RECOGNITION

The nVent LENTON Mechanical Splice System for Steel Reinforcing Bars in Concrete described in ER-0129 and this supplemental report has been evaluated for use as mechanical splices for deformed steel reinforcing bars (rebar) in reinforced concrete structural members. The Mechanical Splice System has been evaluated for structural performance properties, subject to the requirements in ER-0129 and this supplemental report. The Mechanical Splice System was evaluated for compliance with the following codes and regulations:

- 2023 and 2020 City of Los Angeles Building Code (LABC)
- 2023 and 2020 City of Los Angeles Residential Code (LARC)

2.0 LIMITATIONS

Use of the nVent LENTON Mechanical Splice System for Steel Reinforcing Bars in Concrete recognized in this supplement is subject to the following limitations:

2.1 Continuous special inspections of the Mechanical Splice System during installation shall be provided by Registered Deputy Inspectors as required by Section 1705 of the 2023 and 2020 LABC, as applicable. The Registered Deputy Inspector shall verify the following: hardware and equipment; cleaning and condition of the bars in accordance with the specifications and the applicable code; and the installation procedures comply with the specifications and the manufacturer's published installation instructions.

2.2 The fabricator of the steel couplers shall be required to maintain a detailed procedure for material control and suitable procedures and records attesting that the specified coupler has been furnished. The applicable splice designation

(Type 1, Type 2, or Type 2HS) or coating, as applicable, shall be included in each packaging assembly prior to shipment from the fabricator's plant. The fabricator's identification mark designation shall be established and on record prior to fabrication. Couplers that are not identifiable from marking and test records shall be tested to determine conformity to this report. The fabricator shall furnish an affidavit of compliance, and test data shall be provided upon request.

2.3 The nVent LENTON Mechanical Splice System shall be selected at the job site by the Registered Deputy Inspector or by the building inspector and shall be tested by an approved testing agency in accordance with Section 1703 of the LABC. The test shall be conducted on each different rebar size and the frequency of tests shall be as follows: one out of the first ten splices; one out of the next ninety splices; one out of the next one hundred splices. The splice shall develop in tension or compression, as required, at least 125 percent of the specified yield strength of the bar as per Section 25.5.7.1 of ACI 318-19 and -14. For Type 2 splices, the splice shall develop at least 100 percent of the specified tensile strength of the steel reinforcing bar.

For Type 2 splices only, if failure of the tested splice should occur prior to obtaining the 125-percent of the specified yield strength and the 100-percent of the specified tensile strength, then 25-percent of all couplers shall be tested for both specified yield strength and specified tensile strength. If failure of the tested Type 2 splice occurs with testing of the 25-percent requirement, as stated above, then all couplers shall be rejected.

2.4 Minimum concrete cover and spacing between bars or sleeves shall be provided in accordance with Section 1808.8.2 of the 2023 and 2020 LABC.

2.5 The nVent LENTON Mechanical Splice Systems for Steel Reinforcing Bars in Concrete shall be installed in accordance with the applicable code, manufacturer's installation instructions, and this supplement. A copy of the manufacturer's installation instructions or specifications shall be available on-site for all Registered Deputy Inspectors.

2.6 Splice locations shall be noted on the plans approved by the building official. The plans and details shall be prepared stamped, and signed by a California registered design professional, when required by the LABC or LARC.

2.7 Installation procedures and specifications for splicing shall only be performed by qualified operators specified by the manufacturer.

2.8 This supplement expires concurrently with ER-129.

For additional information about this evaluation report please visit www.uniform-es.org or email at info@uniform-es.org