

Surface Snow Melting and Anti-Icing – ElectroMelt System



This step-by-step design guide provides the tools necessary to design an nVent RAYCHEM ElectroMelt heating cable surface snow melting and anti-icing system. For other applications or for design assistance, contact your nVent representative or call (800) 545-6258. Also, visit our web site at nVent.com/RAYCHEM.

Table of Contents

INTRODUCTION	1
How to Use this Guide.....	2
Safety Guidelines	2
Warranty.....	2
SYSTEM OVERVIEW.....	3
Typical System	3
Self-Regulating Heating Cable Construction	4
Approvals.....	5
SURFACE SNOW MELTING AND ANTI-ICING APPLICATIONS	5
SURFACE SNOW MELTING AND ANTI-ICING DESIGN.....	6
Design Step by Step	6
Step 1 Determine design conditions	7
Step 2 Select the heating cable.....	8
Step 3 Determine the required watt density.....	9
Step 4 Determine heating cable spacing.....	11
Step 5 Determine the total area to be protected.....	13
Step 6 Determine heating cable length.....	14
Step 7 Determine the electrical parameters.....	16
Step 8 Select the connection kits and accessories.....	18
Step 9 Select the control system and power distribution.....	21
Step 10 Complete the Bill of Materials.....	27
ELECTROMELT SYSTEM SURFACE SNOW MELTING AND ANTI-ICING DESIGN WORKSHEET.....	28

INTRODUCTION

ElectroMelt heating cable systems can be used as a surface snow melting system when installed in concrete pavement or under paving stones. It can also be used as an anti-icing system but only when installed in concrete pavement.

 **Important:** ElectroMelt is not approved for use in asphalt.

 **Important :** L'ElectroMelt n'est pas approuvé pour une utilisation dans l'asphalte.

If your application conditions are different, or if you have any questions, contact your nVent representative or call (800) 545-6258.

How to Use this Guide

This design guide presents nVent recommendations for designing an ElectroMelt surface snow melting and anti-icing system. It provides design and performance data, electrical sizing information, and heating-cable layout suggestions. Following these recommendations will result in a reliable, energy-efficient system.

Follow the design steps in the section "Surface Snow Melting and Anti-Icing Design" page 6 and use the "ElectroMelt System Surface Snow Melting and Anti-Icing Design Worksheet" page 28 to document the project parameters that you will need for your project's Bill of Materials.

Other Required Documents

This guide is not intended to provide comprehensive installation instructions. For complete ElectroMelt surface snow melting system and anti-icing installation instructions, please refer to the following additional required documents:

- ElectroMelt System Installation and Operation Manual (H58086)
- Additional installation instructions that are included with the connection kits, thermostats, controllers and accessories

If you do not have these documents, you can obtain them from the nVent web site at nVent.com.

For products and applications not covered by this design guide, please contact your nVent representative or call (800) 545-6258.

Safety Guidelines

As with any electrical equipment, the safety and reliability of any system depends on the quality of the products selected and the manner in which they are installed and maintained. Incorrect design, handling, installation, or maintenance of any of the system components could damage the system and may result in inadequate performance, overheating, electric shock, or fire. To minimize these risks and to ensure that the system performs reliably, read and carefully follow the information, warnings, and instructions in this guide.



This symbol identifies important instructions or information.



Ce symbole identifie des instructions ou des informations importantes.



This symbol identifies particularly important safety warnings that must be followed.



Ce symbole identifie des avertissements de sécurité particulièrement importants qui doivent être suivis.



WARNING: To minimize the danger of fire from sustained electrical arcing if the heating cable is damaged or improperly installed, and to comply with the requirements of nVent, agency certifications, and national electrical codes, ground-fault equipment protection must be used on each heating cable branch circuit. Arcing may not be stopped by conventional circuit protection.



AVERTISSEMENT : Pour minimiser le danger d'incendie causé par un arc électrique entretenu, si le câble chauffant est endommagé ou mal installé, et pour respecter les exigences de nVent et celles des codes applicables, il est impératif d'utiliser une protection par disjoncteur différentiel sur chaque circuit alimentant un câble chauffant. Un disjoncteur ordinaire peut ne pas être assez sensible pour prévenir les arcs continus.

Warranty

nVent standard limited warranty applies to nVent RAYCHEM Snow Melting Systems.

An extension of the limited warranty period to ten (10) years from the date of installation is available, except for the control and distribution systems, if a properly completed online warranty form is submitted within thirty (30) days from the date of installation. You can access the complete warranty on our web site at <https://www.nVent.com/RAYCHEM/support/warranty-information>.



SYSTEM OVERVIEW

The ElectroMelt system provides surface snow melting and anti-icing for concrete surfaces and pavement. The ElectroMelt system uses a self-regulating heating cable that reduces heat output automatically as the pavement warms, resulting in lower energy use, and eliminating the possibility of overheating. The system includes heating cable, connection kits, junction boxes, a control system and sensors, power distribution panels, and the tools necessary for a complete installation.

Typical System

A typical system includes the following:

- ElectroMelt self-regulating heating cable
- Connection kits and accessories
- Snow controller and sensors
- Power distribution

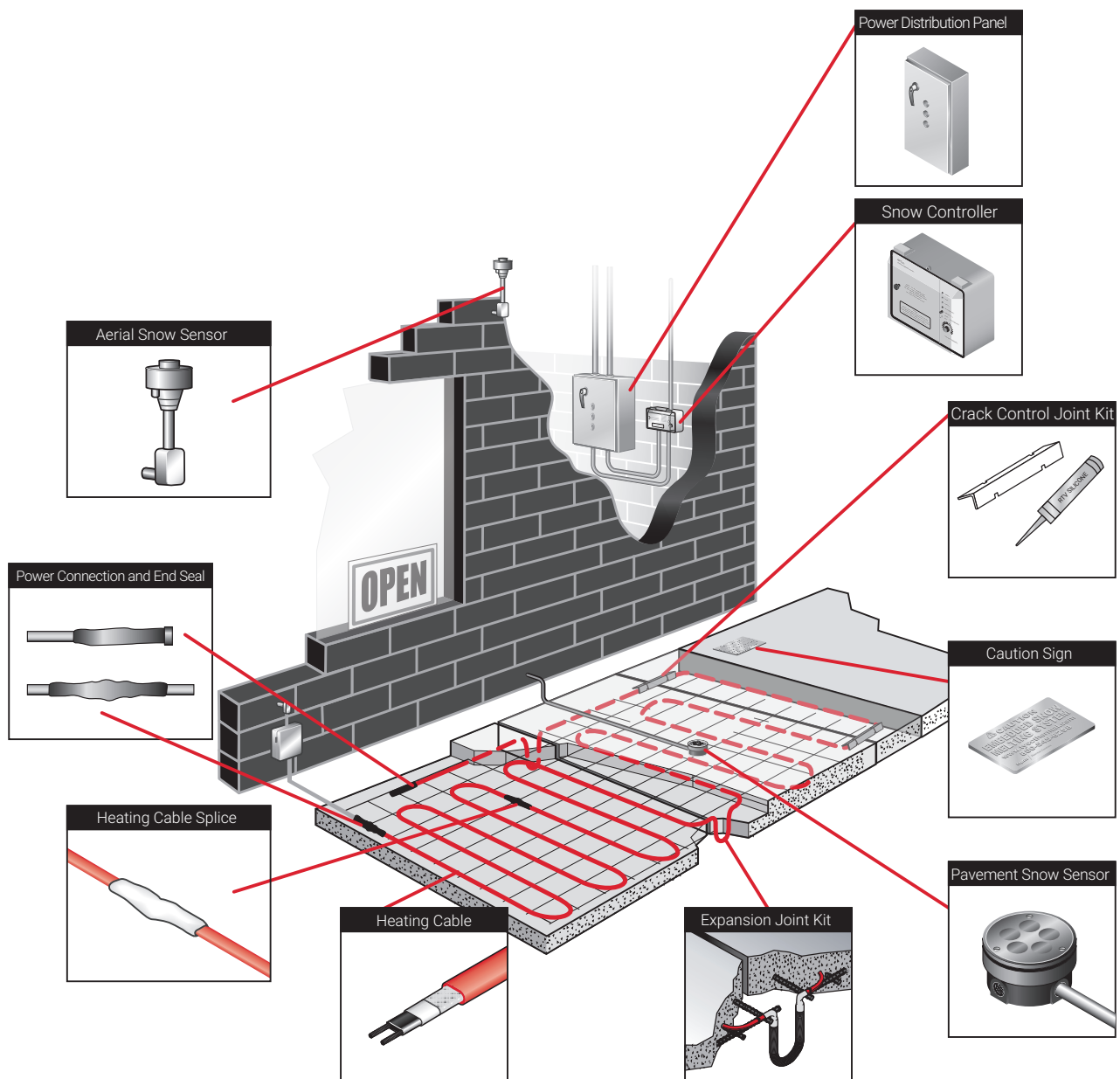

Fig. 1 Typical ElectroMelt system

Self-Regulating Heating Cable Construction

The ElectroMelt self-regulating heating cable is embedded in concrete pavement to melt snow and ice that might otherwise accumulate on the surface. The heating cable responds to the local concrete temperature, increasing heat output when concrete temperature drops and decreasing heat output when concrete temperature rises. The self-regulating heating cable cannot overheat and destroy itself, even if overlapped in the concrete, and therefore does not require the use of overlimit thermostats.

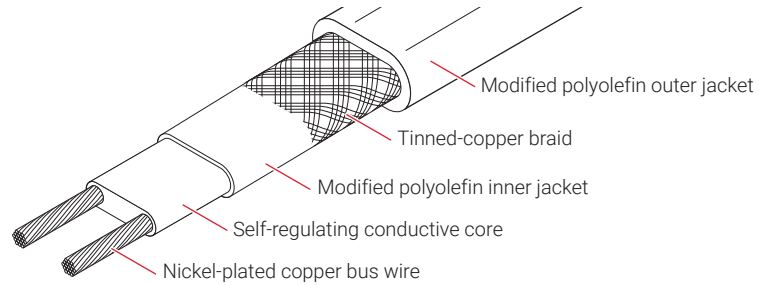

Fig. 2 ElectroMelt heating cable construction

With self-regulating technology, the number of electrical paths between bus wires changes in response to temperature fluctuations. As the temperature surrounding the heater decreases, the conductive core contracts microscopically. This contraction decreases electrical resistance and creates numerous electrical paths between the bus wires. Current flows across these paths to warm the core.

As the temperature rises, the core expands microscopically. This expansion increases electrical resistance and the number of electrical paths decreases. The heating cable automatically reduces its output.

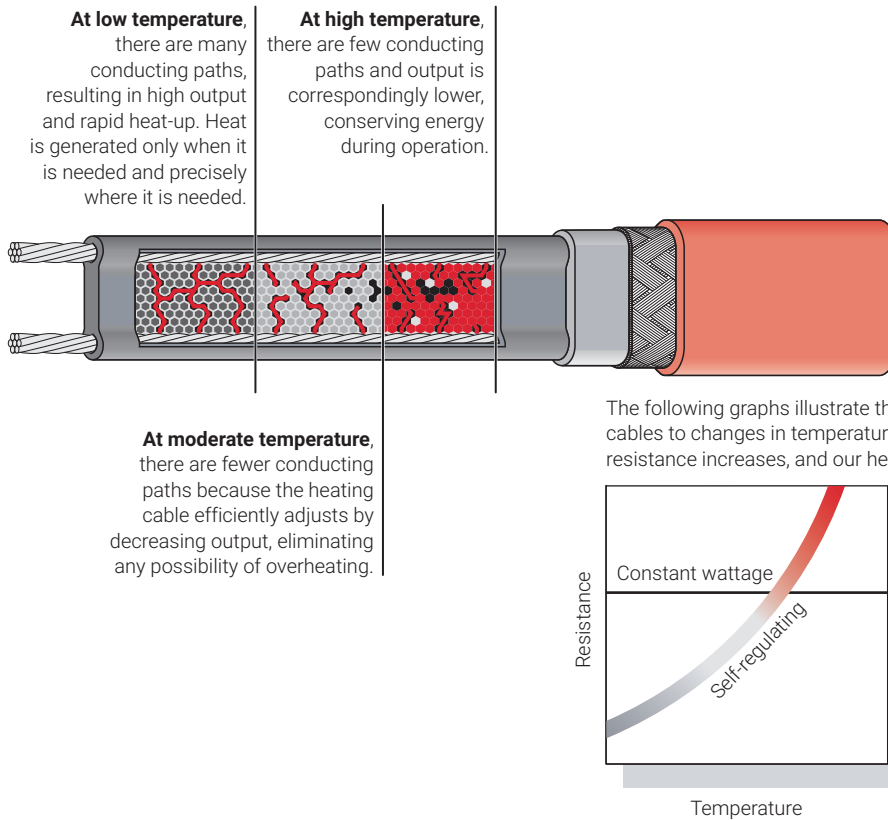

Fig. 3 Self-regulating heating cable technology

Approvals

The ElectroMelt surface snow melting and anti-icing system is c-UL-us Listed for use in nonhazardous locations.



Listed for use with
EM2-XR de-icing and
snow melting system

SURFACE SNOW MELTING AND ANTI-ICING APPLICATIONS

Surface Snow Melting

Surface snow melting systems prevent the accumulation of snow on ramps, slabs, driveways, sidewalks, platform scales, and stairs under most snow conditions.

Anti-Icing

Anti-icing systems keep the surface temperature above freezing at all times to prevent ice formation. Anti-icing applications require a higher watt density and longer hours of operation than a surface snow melting system.

Application Requirements and Assumptions

The design for a standard surface snow melting and anti-icing application is based on the following:

Reinforced Concrete

- 4 to 6 inches (10 to 15 cm) thick
- Placed on grade
- Standard density

Heating cable

- Secured to reinforcement steel or mesh
- Located 1 1/2 to 2 inches (4 to 6 cm) below finished surface

Pavers

- Concrete pavers 1 to 1 1/2 (2.5 to 4 cm) inches thick
- Placed on concrete or mortar base on grade

Heating cable

- Secured to mesh
- Embedded in concrete or mortar base below the pavers

For products and applications not covered by this guide, contact your nVent representative for design assistance. Using proprietary computer modeling, nVent can design the appropriate system for these applications.

The following are examples of applications not addressed in this design guide:

- Concrete thinner than 4 inches (10 cm)
- Concrete thicker than 6 inches (15 cm)
- Lightweight concrete
- Concrete with pavers thicker than 1 1/2 inches (4 cm)
- Ramps and walkways with air below
- Concrete without reinforcement
- Retrofitting of heating cable to existing pavement
- Pavers composed of material other than concrete



This section details the steps necessary to design your application. The examples provided in each step are intended to incrementally illustrate sample designs from start to finish. As you go through each step, use the "ElectroMelt System Surface Snow Melting and Anti-Icing Design Worksheet" page 28 to document your project parameters, so that by the end of this section you will have the information you need for your Bill of Materials.

SnoCalc is an online design tool available to help you create surface snow melting designs and layouts. It is available at nVent.com.

Design Step by Step

Your system design requires the following essential steps:

- 1 Determine design conditions
- 2 Select the heating cable
- 3 Determine the required watt density
- 4 Determine heating cable spacing
- 5 Determine the total area to be protected
- 6 Determine heating cable length
- 7 Determine the electrical parameters
- 8 Select the connection kits and accessories
- 9 Select the control system and power distribution
- 10 Complete the Bill of Materials

Surface Snow Melting and Anti-Icing
1. Determine design conditions
2. Select the heating cable
3. Determine the required watt density
4. Determine heating cable spacing
5. Determine the total area to be protected
6. Determine heating cable length
7. Determine the electrical parameters
8. Select the connection kits and accessories
9. Select the control system and power distribution
10. Complete the Bill of Materials

Step 1 Determine design conditions

Collect the following information to determine your design conditions:

- Application (surface snow melting or anti-icing)
- Environment
 - For surface snow melting: Geographical location
 - For anti-icing: Minimum ambient temperature and average wind speed
- Paving material
- Size and layout
 - Slab surface area
 - Ramp surface area
 - Stairs
 - Number of stairs
 - Width of stair
 - Riser height
 - Depth of stair
 - Landing dimensions
 - Wheel tracks
 - Track length
 - Concrete joints
 - Surface drains
 - Location of area structures
 - Other information as appropriate
- Supply voltage
- Automatic or manual control method



Note: Drainage must be a primary concern in any snow melting system design. Improper drainage can result in ice formation on the surface of the heated area once the system is de-energized. Ice formation along the drainage path away from the heated area may create an ice dam and prohibit proper draining. If your design conditions may lead to drainage problems, please contact nVent Technical Support for assistance.



Remarque : Le drainage doit être une préoccupation majeure dans la conception de tout système de déneigeage. Un mauvais drainage peut entraîner la formation de glace à la surface de la zone chauffée une fois que le système est hors tension. La formation de glace le long de la voie de drainage, loin de la zone chauffée, peut créer une digue de glace et empêcher le bon drainage. Si vos conditions de conception peuvent entraîner des problèmes de drainage, veuillez contacter le soutien technique nVent pour obtenir de l'aide.

Prepare Scale Drawing

Draw to scale the snow melting area and note the rating and location of the voltage supply. Include stairs and paths for melting water runoff. Show concrete joints, surface drains, and location of area structures including post installations for railings, permanent benches, and flagpoles. Measurements for each distinct section of the snow melting application, including stairs, will allow for an accurate system design, including control configuration. Use these symbols to indicate the heating cable expansion and crack-control joints:

- Expansion joint
- — — Crack-control joint
-  — Expansion joint kit

Fig. 4 Design symbols

Example: Surface Snow Melting System

Application	Surface snow melting
Geographical location	Buffalo, NY
Size and layout	80 ft x 50 ft (24.4 m x 15.2 m)
Paving material	Concrete slab
Stairs:	
Number of stairs	10
Width of stair	5 ft (1.5 m)
Riser height	6 in (15 cm)
Depth of stair	12 in (30 cm)
Supply voltage	277 V
Phase	Single-phase
Control method	Automatic snow melting controller

Example: Anti-Icing System

Application	Anti-icing
Minimum ambient temperature	10°F (-12°C)
Average wind speed	20 mph (32 kmph)
Size and layout	80 ft x 50 ft (24.4 m x 15.2 m)
Paving material	Concrete slab
Stairs:	
Number of stairs	10
Width of stair	5 ft (1.5 m)
Riser height	6 in (20 cm)
Depth of stair	12 in (30 cm)
Supply voltage	277 V
Phase	Single-phase
Control method	Slab sensing thermostat

Surface Snow Melting and Anti-Icing
1. Determine design conditions
2. Select the heating cable
3. Determine the required watt density
4. Determine heating cable spacing
5. Determine the total area to be protected
6. Determine heating cable length
7. Determine the electrical parameters
8. Select the connection kits and accessories
9. Select the control system and power distribution
10. Complete the Bill of Materials

Step 2 Select the heating cable

nVent offers one self-regulating heating cable with the ElectroMelt system. ElectroMelt heating cables must only be powered by single phase voltage. In applications where the power supply is three-phase, all circuits must be wired to provide single-phase voltage to the heating cables.

Table 1 ElectroMelt Self-Regulating Heating Cable

Supply voltage	Catalog number
208 V, 240 V, 277 V	EM2-XR

Example (continued): Surface Snow Melting System

Supply voltage	277 V (from Step 1)
Heating cable	EM2-XR

Example (continued): Anti-Icing System

Supply voltage	277 V (from Step 1)
Heating cable	EM2-XR

Surface Snow Melting and Anti-Icing
1. Determine design conditions
2. Select the heating cable
3. Determine the required watt density
4. Determine heating cable spacing
5. Determine the total area to be protected
6. Determine heating cable length
7. Determine the electrical parameters
8. Select the connection kits and accessories
9. Select the control system and power distribution
10. Complete the Bill of Materials

Step 3 Determine the required watt density

Surface Snow Melting

For maximum performance from any snow melting system, you must first take into account the local snowfall and icing patterns. A system design that works well in one city may be inadequate in another. The energy required to melt snow varies with air temperature, wind speed, relative humidity, snow density, and the depth of the snow on the pavement.

Table 2 summarizes the required watt density for most major cities in North America based on typical minimum ambient temperatures and the snowfall and icing patterns. Select the city from the list, or closest city, where similar climatic conditions exist.

Table 2 Required Watt Density for Surface Snow Melting

City	Watts/ft ²		Watts/m ²	
	Concrete	Pavers	Concrete	Pavers
USA				
Baltimore, MD	35	40	377	431
Boston, MA	35	40	377	431
Buffalo, NY	40	45	431	484
Chicago, IL	35	40	377	431
Cincinnati, OH	35	40	377	431
Cleveland, OH	35	40	377	431
Denver, CO	35	40	377	431
Detroit, MI	35	40	377	431
Great Falls, MT	50	50	538	538
Greensboro, NC	35	35	377	377
Indianapolis, IN	35	40	377	431
Minneapolis, MN	50	50	538	538
New York, NY	35	40	377	431
Omaha, NE	45	50	484	538
Philadelphia, PA	35	40	377	431
Salt Lake City, UT	35	35	377	377
Seattle, WA	35	35	377	377
St. Louis, MO	35	40	377	431
Canada				
Calgary, AB	45	45	484	484
Edmonton, AB	50	50	538	538
Fredericton, NB	40	45	431	484
Halifax, NS	35	40	377	431
Moncton, NB	40	40	431	431
Montreal, QC	45	45	484	484
Ottawa, ON	45	45	484	484
Prince George, BC	50	55	538	592
Quebec, QC	45	45	484	484
Regina, SK	50	55	538	592
Saskatoon, SK	50	50	538	538
St. John, NB	40	45	431	484
St. John's, NF	35	35	377	377
Sudbury, ON	40	45	431	484
Thunder Bay, ON	50	55	538	592
Toronto, ON	35	40	377	431
Vancouver, BC	35	40	377	431
Winnipeg, MB	50	55	538	592

Note: To provide faster heat-up, the required watt density in Table 2 is greater than what is suggested by ASHRAE.

Example (continued): Surface Snow Melting System

Geographical location Buffalo, NY (from Step 1)

Required watt density **40 W/ft² (431 W/m²)** (from Table 2)

Anti-Icing

From the minimum ambient temperature and average wind speed that you determined in Step 1 for your anti-icing application, use the tables below to determine the required watt density for that application.

Table 3 Required Watt Density for Ice-Free Surfaces W/ft²

Minimum ambient temperature	Average wind speed during freezing periods			
	5 mph	10 mph	15 mph	20 mph
20°F	30	30	35	40
10°F	30	30	35	45
0°F	30	40	45	60
-10°F	30	45	60	80
-20°F	35	55	80	–
-30°F	40	65	–	–
-40°F	45	75	–	–

Table 4 Required Watt Density for Ice-Free Surfaces W/m²

Minimum ambient temperature	Average wind speed during freezing periods			
	8 kmph	16 kmph	24 kmph	32 kmph
-7°C	323	323	377	431
-12°C	323	323	377	484
-18°C	323	431	484	646
-23°C	323	484	646	861
-29°C	377	592	861	–
-34°C	431	699	–	–
-40°C	484	807	–	–

 **Note:** This procedure is derived from finite model studies of 4-inch slabs and is applicable to standard concrete pavement from 4 to 6 inches thick placed directly on grade. If your application involves other materials or construction, contact your nVent representative.

 **Remarque :** Cette procédure est conçue sur la base d'études de modèles finis de dalles de 4 po (10,2 cm) et est applicable aux chaussées en béton standard de 4 à 6 po (10,2 à 15,2 cm) d'épaisseur placées directement sur le sol. Si votre utilisation implique d'autres matériaux ou constructions, contactez votre représentant nVent.

Example (continued): Anti-Icing System

Minimum ambient temperature

10°F (-12°C) (from Step 1)

Average wind speed

20 mph (32 kmph) (from Step 1)

Required watt density

45 W/ft² (484 W/m²)
(from Table 3 and Table 4)

Surface Snow Melting and Anti-Icing
1. Determine design conditions
2. Select the heating cable
3. Determine the required watt density
4. Determine heating cable spacing
5. Determine the total area to be protected
6. Determine heating cable length
7. Determine the electrical parameters
8. Select the connection kits and accessories
9. Select the control system and power distribution
10. Complete the Bill of Materials

Step 4 Determine heating cable spacing

Surfaces

To determine your heating cable spacing, you need to know your applications's power output and required watt density.

The power output from the ElectroMelt heating cable depends on the supply voltage used in the application. Table 5 lists power output per linear foot of heating cable determined by the supply voltage. Divide this figure by the required watt density that you determined in Step 3. You will get the required heating cable spacing in feet or meters as applicable. Multiply this figure by 12 inches or by 100 centimeters to determine your heating cable spacing.

Table 5 Heating Cable Spacing in Concrete

Supply voltage	Catalog number	Power output W/ft (W/m)
208 V	EM2-XR	30 (98)
240 V	EM2-XR	32 (105)
277 V	EM2-XR	34 (112)

To determine cable spacing required for surface snow melting and anti-icing

$$\text{Heating cable spacing (in)} = \frac{(\text{W/ft power output of cable per Table 5}) \times 12 \text{ in}}{\text{W/ft}^2 \text{ requirement from Step 3}}$$

$$\text{Heating cable spacing (cm)} = \frac{(\text{W/m power output of cable per Table 5}) \times 100 \text{ cm}}{\text{W/m}^2 \text{ requirement from Step 3}}$$

Round answer to nearest whole number of inches or centimeters.

Example (continued): Surface Snow Melting System

Supply voltage	277 V (from Step 1)
Heating cable	EM2-XR (from Step 2)
Power output	34 W/ft (112 W/m ²) (from Table 5)
Spacing	$(34 \text{ W/ft} \times 12 \text{ in}) / 40 \text{ W/ft}^2 = \mathbf{10.2 \text{ in}}$ Rounded to 10 in

$$(112 \text{ W/m} \times 100 \text{ cm}) / 431 \text{ W/m}^2 = 26 \text{ cm}$$

Example (continued): Anti-Icing System

Supply voltage	277 V (from Step 1)
Heating cable	EM2-XR (from Step 2)
Power output	34 W/ft (from Table 5)
Spacing	$(34 \text{ W/ft} \times 12 \text{ in}) / 45 \text{ W/ft}^2 = \mathbf{9.1 \text{ in}}$ Rounded to 9 in

$$(112 \text{ W/m} \times 100 \text{ cm}) / 484 \text{ W/m}^2 = 23.1 \text{ cm}$$

Rounded to 23 cm

Stairs

Heat loss in stairs occurs from the two exposed surfaces: the top of the stair and its side. Watt density requirements are therefore greater for snow melting and anti-icing. Rather than calculating heating cable spacing in the stair, refer to Table 6 and determine the number of runs of heating cable per stair based on the depth of the stair. Space the heating cable evenly across the depth of the stair with one run 2 in (5 cm) from the front, or nose, of the stair. This method will provide sufficient watt density for both snow melting and anti-icing.

Table 6 Heating cable runs per stair

Stair depth	Number of cable runs per stair
Less than 10.5 in (27 cm)	2
10.5–12 in (27–30 cm)	2

For landings in the stairway, use cable spacing as calculated for surfaces. As with stairs, a run of heating cable must be placed 2 in (5 cm) from the exposed edge of the landing leading to the stairs.

Anticipate and design for the addition of railings or other follow on construction that will require cutting or drilling into the concrete as damage to installed heating cable may occur. Allow for at least 4 inches clearance between the heating cable and any planned cuts or holes.

Example (continued): Surface Snow Melting and Anti-Icing System

Depth of stair	12 in (30 cm) (from Step 1)
Number of cable runs per stair	2 runs
Spacing	Equally spaced across the width of the stair with one run 2 in (5 cm) from the front edge

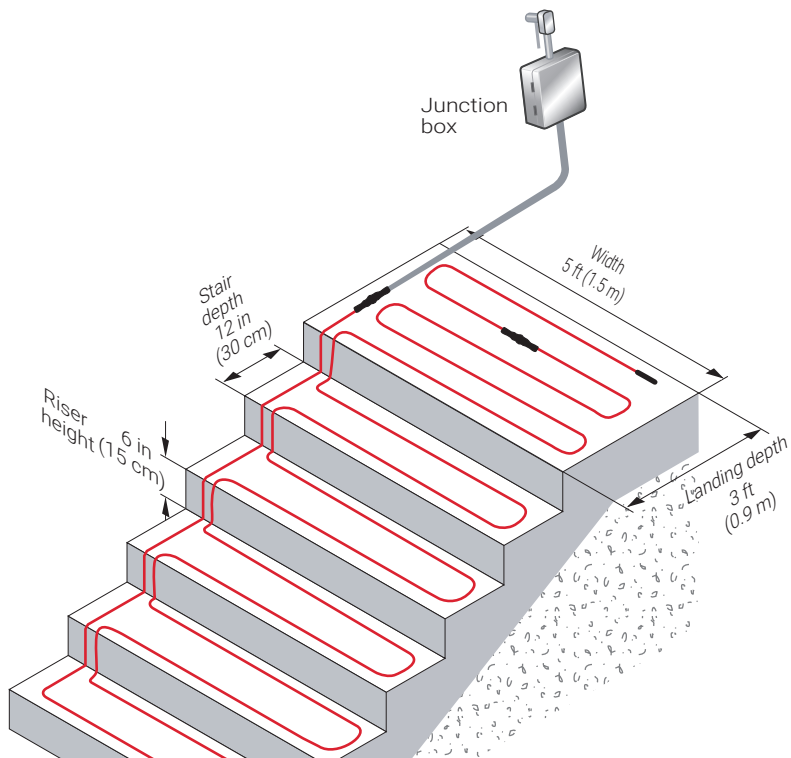

Fig. 5 Typical heating cable layout for concrete stairs

Surface Snow Melting and Anti-Icing
1. Determine design conditions
2. Select the heating cable
3. Determine the required watt density
4. Determine heating cable spacing
5. Determine the total area to be protected
6. Determine heating cable length
7. Determine the electrical parameters
8. Select the connection kits and accessories
9. Select the control system and power distribution
10. Complete the Bill of Materials

Step 5 Determine the total area to be protected

Surfaces

To determine the total amount of heating cable, you need to determine the surface area you will be protecting from snow and ice accumulation. If assistance is required in designing for irregular shaped areas, please contact your nVent representative.

Example: Surface Snow Melting System

Total area of concrete slab $80 \text{ ft} \times 50 \text{ ft} = 4000 \text{ ft}^2$
 $(24.4 \text{ m} \times 15.2 \text{ m} = 370.8 \text{ rounded to} = 371 \text{ m}^2)$

Example: Anti-Icing System

Total area of concrete slab $80 \text{ ft} \times 50 \text{ ft} = 4000 \text{ ft}^2$
 $(24.4 \text{ m} \times 15.2 \text{ m} = 370.8 \text{ rounded to} = 371 \text{ m}^2)$

Wheel Tracks

To reduce power consumption for concrete driveways, it may be sufficient to provide snow melting for only the wheel tracks.

Design wheel track applications with the same spacing used for concrete slabs. Heating cable should run to the edge of each side of the wheel track and be laid in a serpentine pattern along the length of the wheel track.

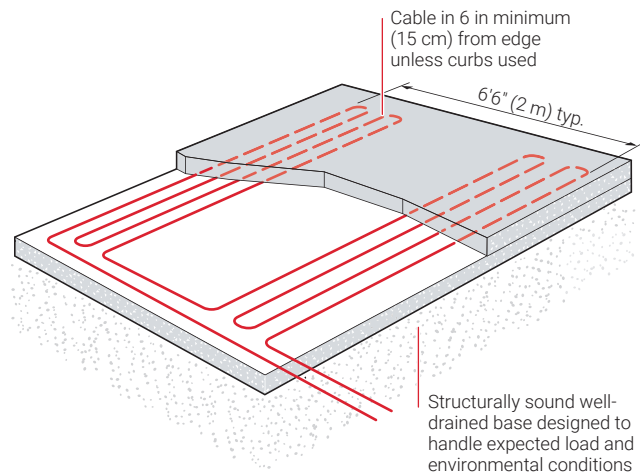

Fig. 6 Wheel track example

Stairs

Surface area of the stairs is not required to determine heating cable required.

Surface Snow Melting and Anti-Icing
1. Determine design conditions
2. Select the heating cable
3. Determine the required watt density
4. Determine heating cable spacing
5. Determine the total area to be protected
6. Determine heating cable length
7. Determine the electrical parameters
8. Select the connection kits and accessories
9. Select the control system and power distribution
10. Complete the Bill of Materials

Step 6 Determine heating cable length

Surfaces

Calculate the heating cable length by dividing the total heated area by the heating cable spacing calculated in the previous steps. In Step 8, you will need to add additional heating cable for accessories which will then give you the total heating cable length.

Calculate the heating cable length for the surface as follows:

$$\text{Heating cable length} = \frac{\text{Heated area (ft}^2\text{)} \times 12}{\text{Heating cable spacing (in)}}$$

$$\text{Heating cable length} = \frac{\text{Heated area (m}^2\text{)} \times 100}{\text{Heating cable spacing (cm)}}$$

Example (continued): Surface Snow Melting System for Concrete Slab

Total area of concrete slab	4000 ft ² (371 m ²) (from Step 5)
Cable spacing	10 in (26 cm) (from Step 4)
	(4000 ft ² x 12 in) / 10 in spacing = 4800 ft
	(371 m ² x 100 cm) / 26 cm spacing = 1427 m
Heating cable length	4800 ft (1427 m)

Example (continued): Anti-Icing System for Concrete Slab

Total area of concrete slab	4000 ft ² (371 m ²) (from Step 5)
Cable spacing	9 in (23 cm) (from Step 4)
	(4000 ft ² x 12 in) / 9 in spacing = 5333 ft
	(371 m ² x 100 cm) / 23 cm spacing = 1613 m
Heating cable length	5333 ft (1613 m)

Stairs

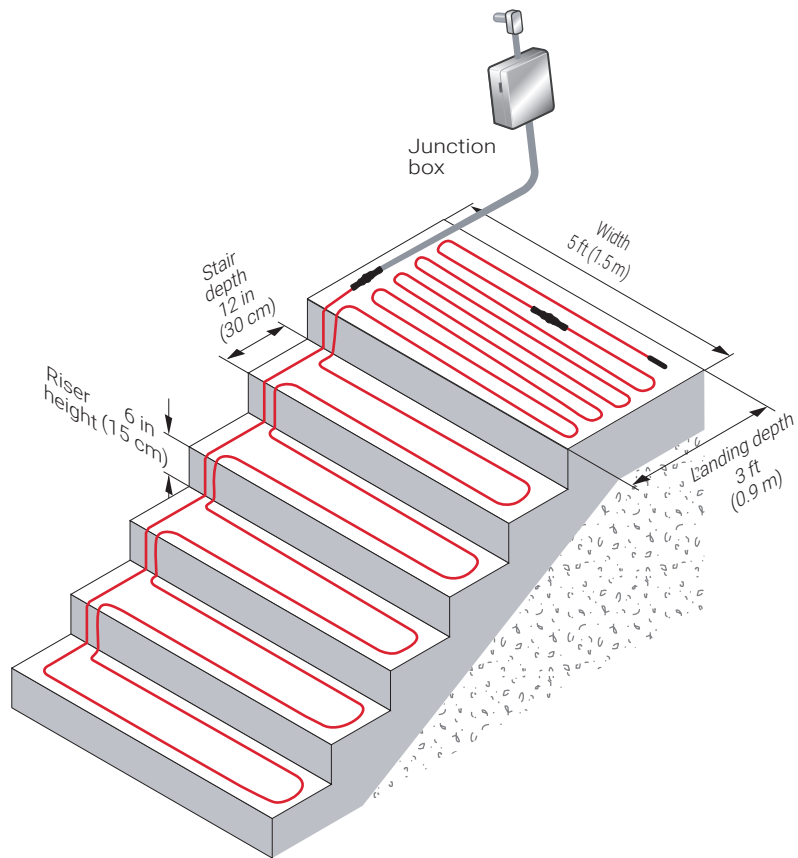

Fig. 7 Concrete stair example

Use the formula below to determine the length of cable required for stairs. Stair area is not needed for the cable length calculation. Two runs of heating cable will be installed per stair as determined in Step 4. For landing areas, use the equation for surfaces.

Length of cable = No. of stairs x [(No. runs per stair x width of stair) + (2 x riser height)]
for stair (ft) (m)

Example (continued): Surface Snow Melting and Anti-Icing System for Stairs

Number of stairs	10 stairs (from Step 1)
Number of cable runs per stair	2 runs
Width of stair	5 ft (1.5 m) (from Step 1)
Riser height	6 in (15 cm) convert to 0.5 ft (0.15 m) (from Step 1)
	10 stairs x [(2 x 5 ft) + (2 x 0.5 ft)] = 110 ft
	10 stairs x [(2 x 1.5 m) + (2 x 0.15 m)] = 33 m
Heating cable length	110 ft (33 m)

For applications where the landing area is very large or where an expansion joint exists between the stairs and landing, consider the stairs and landing as two separate areas. In these cases, determine the length of cable required for the stairs as shown earlier in this section and select the cable for the landing as shown for ramps, slabs, driveways, sidewalks, platform scales.

Surface Snow Melting and Anti-Icing
1. Determine design conditions
2. Select the heating cable
3. Determine the required watt density
4. Determine heating cable spacing
5. Determine the total area to be protected
6. Determine heating cable length
7. Determine the electrical parameters
8. Select the connection kits and accessories
9. Select the control system and power distribution
10. Complete the Bill of Materials

Step 7 Determine the electrical parameters

This section will help you determine the electrical parameters for an ElectroMelt system including circuit breaker sizing and maximum circuit length. Total required heating cable length divided by maximum circuit length will determine the number of circuits required for your snow melting solution.

Determine Maximum Circuit Length

To determine maximum circuit length, it is important to establish a minimum startup temperature for the system. The following tables provide maximum circuit lengths based on minimum startup temperature, circuit breaker rating, and supply voltage. Colder temperature startup requires shorter maximum circuit lengths. The use of an automatic system, which energizes the system above 20°F (-7°C), ensures that you can use maximum circuit lengths. Manual control systems may require you to use shorter circuit lengths to compensate for startup below 20°F (-7°C).

A 30-mA ground-fault protection device (GFPD) must be used to provide protection from arcing or fire, and to comply with warranty requirements, agency certifications, and national electrical codes. If the heating cable is improperly installed, or physically damaged, sustained arcing or fire could result. If arcing does occur, the fault current may be too low to trip conventional circuit breakers.

Table 7 Maximum Circuit Length for Startup at 20°F (-7°C) in Feet (Meters) using an Automatic Snow Control System

Circuit Breaker (A)	Heating cable supply voltage		
	208 V	240 V	277 V
15	80 (24)	85 (26)	100 (31)
20	105 (32)	115 (35)	130 (40)
30	160 (49)	170 (52)	195 (59)
40	210 (64)	230 (70)	260 (79)
50	265 (81)	285 (87)	325 (99)

Table 8 Maximum Circuit Length for Startup at 0°F (-18°C) in Feet (Meters) using a Manual Control System

Circuit Breaker (A)	Heating cable supply voltage		
	208 V	240 V	277 V
15	75 (23)	80 (24)	90 (27)
20	100 (31)	110 (34)	120 (37)
30	145 (44)	160 (49)	180 (55)
40	200 (61)	210 (64)	240 (73)
50	245 (75)	265 (81)	300 (91)

⚠ WARNING: To minimize the danger of fire from sustained electrical arcing if the heating cable is damaged or improperly installed, and to comply with the requirements of nVent, agency certifications, and national electrical codes, ground-fault equipment protection must be used on each heating cable branch circuit. Arcing may not be stopped by conventional circuit protection.

⚠ AVERTISSEMENT : Pour réduire le danger d'incendie causé par un arc électrique continu, si le câble chauffant est endommagé ou mal installé, et pour être conforme avec nVent, les organismes de certification et les codes applicables, il est impératif d'utiliser une protection par disjoncteur différentiel. Un disjoncteur ordinaire peut ne pas être assez sensible pour prévenir les arcs continus.

Example (continued): Surface Snow Melting and Anti-Icing System with Automatic Snow Control

Startup temperature	20°F (-7°C) (from Step 1)
Circuit breakers	50 A
Supply voltage	277 V (from Step 1)
Maximum circuit length	325 ft (99 m) (from Table 7)

Determine number of circuits

Use the following formula to determine number of circuits for the system:

$$\text{Number of circuits} = \frac{\text{Heating cable length required}}{\text{Maximum heating cable circuit length}}$$

Example (continued): Surface Snow Melting

Surfaces

Total heating cable length	4800 ft (1427 m) (from Step 6)
Maximum circuit length	325 ft (99 m) (from above)
Number of circuits	$4800 / 325 = 14.8$ rounded to 15 circuits

Stairs

Total heating cable length	110 ft (33 m) (from Step 6)
Maximum circuit length	325 ft (99 m) (from above)
Number of circuits	$110 / 325 = 0.3$ rounded to 1 circuit

Example (continued): Anti-Icing System

Surfaces

Total heating cable length	5333 ft (1613 m) (from Step 6)
Maximum circuit length	325 ft (99 m)
Number of circuits	$5333 / 325 = 16.4$ rounded to 17 circuits

Stairs

Total heating cable length	110 ft (33 m) (from Step 6)
Maximum circuit length	325 ft (99 m) (from above)
Number of circuits	$110 / 325 = 0.3$ rounded to 1 circuit

Determine Transformer load

The total transformer load is the sum of load on all the circuit breakers in the system.

Calculate the Circuit Breaker Load (CBL) as:

$$\text{CBL (kW)} = \frac{\text{Circuit breaker rating (A)} \times 0.8 \times \text{Supply voltage}}{1000}$$

Calculate the Total Transformer Load as follows:

If the CBL is equal on all circuit breakers, calculate the Total Transformer Load as:

$$\text{Total Transformer Load (kW)} = \text{CBL} \times \text{Number of circuits}$$

If the CBL is not equal on all circuit breakers, calculate the Total Transformer Load as:

$$\text{Total Transformer Load (kW)} = \text{CBL}_1 + \text{CBL}_2 + \text{CBL}_3 \dots + \text{CBL}_N$$

Example: Surface Snow Melting

Circuit breaker load $(50 \text{ A} \times 0.8 \times 277 \text{ V}) / 1000 = 11.1 \text{ kW}$
Transformer Load $11.1 \text{ kW} \times 16 \text{ circuits} = 177.6 \text{ kW}$ rounded to **178 kW**

Example: Anti-Icing System

Circuit breaker load $(50 \text{ A} \times 0.8 \times 277 \text{ V}) / 1000 = 11.1 \text{ kW}$
Transformer load $11.1 \text{ kW} \times 18 \text{ circuits} = 199.8 \text{ kW}$ rounded to **200 kW**

Surface Snow Melting and Anti-Icing
1. Determine design conditions
2. Select the heating cable
3. Determine the required watt density
4. Determine heating cable spacing
5. Determine the total area to be protected
6. Determine heating cable length
7. Determine the electrical parameters
8. Select the connection kits and accessories
9. Select the control system and power distribution
10. Complete the Bill of Materials







Step 8 Select the connection kits and accessories

nVent provides all the connection kits and accessories necessary to satisfy code, approval agency, and warranty requirements for the ElectroMelt system. Additional heating cable will be required for connection kits, splices, expansion joint kits, and end terminations. Adding the additional heating cable allowances needed with the heating cable length required for the layout will give you the total heating cable length required.

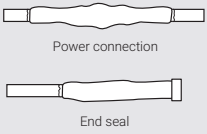
Prepare a drawing of your system showing distinct circuits, layout of cables, connection kits, expansion joints, drains, heated pathways for meltwater, power connections, junction boxes, and sensors. Determine length of cold lead power cables from slab for power connections for all circuits. If possible, avoid crossing expansion, crack control, or other pavement joints. Use the nVent RAYCHEM EMK-XEJ expansion joint kit to protect the heating cable if crossing is unavoidable. The numbers of crack control joints crossed should be minimized per circuit. The heating cable needs to be secured to an 18" or longer, #5 or larger rebar with plastic tie wrap or protected with an nVent RAYCHEM EMK-XCJ as shown in Figure 2 to provide protection against shearing.

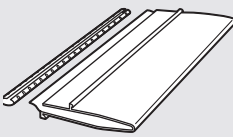
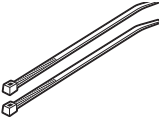
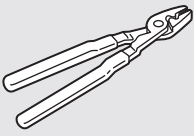
Junction boxes must be mounted above grade to prevent water entry. Use a Listed nVent RAYCHEM EMK-JB or equivalent UL Listed or CSA Certified weatherproof junction box. The 8 AWG power cable included in the nVent RAYCHEM EMK-XC kit must be run from a junction box through a UL Listed or CSA Certified weatherproof 1 inch rigid metal conduit which must extend into the slab. The EMK-XC power connection must be placed within the slab such that the connection is near but outside of the end of the conduit. The exposed section of power cable is covered with an additional piece of heat shrink tubing to prevent concrete from contacting the cable.

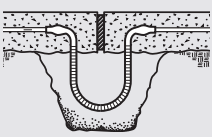
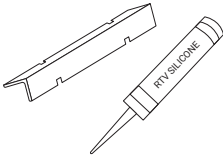
Table 9 Connection Kits and Accessories

	Catalog number	Description	Standard packaging	Usage	Heating cable allowance ¹
Connection Kits					
 <p>Power connection</p> <p>End seal</p>	EMK-XC-USA EMK-XC-CAN	Power connection and end seal kit	1	1 per circuit	1 ft (30 cm) for power connection and 0.3 ft (9 cm) for end seal
	EMK-XS	Splice kit	1	As required	1 ft (30 cm)
Accessories					
	EMK-XJR	Jacket repair kit	1	As required	–
	EMK-CT	Nylon cable ties	100/pack	1 per foot of cable used	–
	EMK-XT	Crimping tool	1	–	–
	SMCS	Snow melt caution sign Dimensions: 6 x 4 in (150 x 100 mm)	1	1 minimum per system	–
	EMK-XEJ	Expansion joint kit	1	1 per expansion joint crossing	1 1/2 ft (45 cm)
	EMK-XCJ	Crack control joint kit	1	1 per crack control joint crossing	–
	EMK-JB	Junction box Dimensions: 6 x 6 x 4 in (152 x 152 x 102 mm)	1		Maximum of 2 circuits per EMK-JB

¹Allow extra heating cable for ease of component installation.

Example: Surface Snow Melting System

Number of circuits 15 for concrete slab + 1 for stairs = 16
Power connection kits 16 power connection kits
Conduit length (from slab to junction box) 15 ft (4.5 m)

Heating cable allowance for each power connection and end seal
1.3 ft x 16 circuits = 20.8 ft
0.39 m x 16 circuits = 6.3 m

Total heating cable length required **21 ft (7 m)**

Example: Anti-Icing System

Number of circuits 17 for concrete slab + 1 for stairs = 18
Power connection kits 18 power connection kits
Conduit length (from slab to junction box) 15 ft (4.5 m)

Heating cable allowance for each power connection and end seal
1.3 ft x 18 circuits = 23.4 ft
0.39 m x 18 circuits = 7.1 m

Total heating cable length required **24 ft (8 m)**

Surface Snow Melting and Anti-Icing
1. Determine design conditions
2. Select the heating cable
3. Determine the required watt density
4. Determine heating cable spacing
5. Determine the total area to be protected
6. Determine heating cable length
7. Determine the electrical parameters
8. Select the connection kits and accessories
9. Select the control system and power distribution
10. Complete the Bill of Materials

Step 9 Select the control system and power distribution

Control Systems

Select a control system from the following three options, but keep in mind that an automatic snow controller offers the highest system efficiency and the lowest operating cost.

- Manual on/off control
- Slab sensing thermostat
- Automatic snow melting controller

If the current rating of the control means is exceeded, all three methods will require contactors sized to carry the load. Each method offers a tradeoff balancing initial cost versus energy efficiency and ability to provide effective snow melting. If the system is not energized when required, snow will accumulate. If the system is energized when it is not needed, there will be unnecessary power consumption. Choose the control method that best meets the project performance requirements. For additional information, refer to the "Typical Control Diagrams," Table 10, or contact your nVent representative for details.

Controller systems shall be Listed and shall be suitably rated for the snow melting system and anti-icing installation. Contact nVent to determine suitability.

Manual On/Off Control

A manually controlled system is operated by a switch that controls the system power contactor. This method requires constant supervision to work effectively.

A manual system can be controlled by a building management system.

Slab Sensing Thermostat

A slab sensing thermostat can be used to energize the system whenever the slab temperature is below freezing, but is not energy efficient when used as the sole means of control. The slab sensing thermostat is recommended for all snow melting applications, even when an automatic snow controller is used, and is required for all paver installations.

Automatic Snow Melting Controller

With an automatic snow controller, the snow melting system is automatically energized when both precipitation and low temperature are detected. When precipitation stops or the ambient temperature rises above freezing, the system is de-energized. In addition, a slab sensor de-energizes the system after the slab reaches the slab sensing set point even if freezing precipitation is still present. Using an automatic snow controller with a slab sensor offers the most energy-efficient control solution.

For areas where a large number of circuits are required, the nVent RAYCHEM ACS-30 can be used. The Surface Snow Melting control mode in the ACS-30 includes an External Device control option. This option allows a Snow/Moisture sensing controller (from Table 10) to be integrated into the ACS-30 system. Note that sensors (snow or gutter) cannot be directly connected to the ACS-30 system. Refer to the ACS-30 Programming Guide (H58692) for more information on system setup.

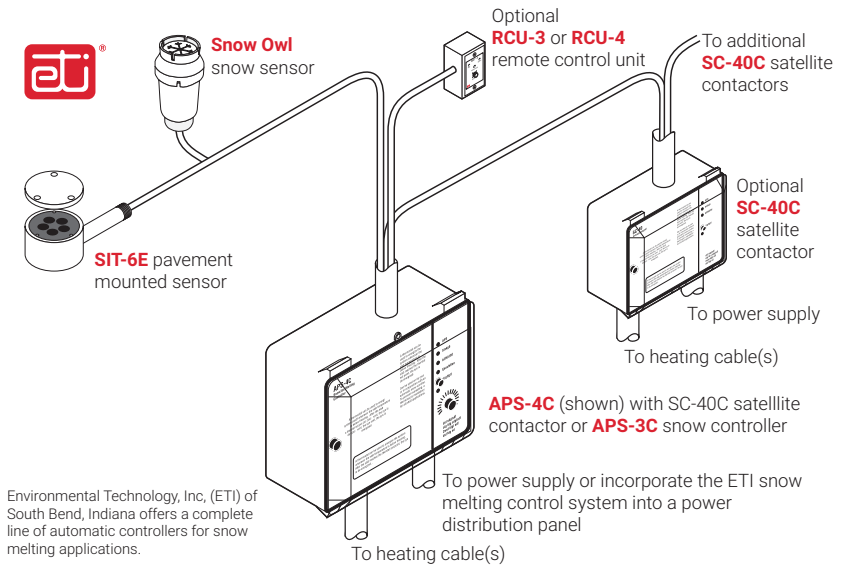

Fig. 8 Automatic snow melting control system

Table 10 Control Systems



	Catalog number	Description
Slab Sensing Thermostat		
	ECW-GF	Electronic ambient sensing controller with 30-mA ground-fault protection. The controller can be programmed to maintain temperatures up to 200°F (93°C) at voltages from 100 to 277 V and can switch current up to 30 Amperes. The ECW-GF is complete with a 25-ft (7.6-m) temperature sensor and is housed in a Type 4X rated enclosure. The controller features an AC/DC dry alarm contact relay. An optional ground-fault display panel (ECW-GF-DP) that can be added to provide ground-fault or alarm indication in applications where the controller is mounted in inaccessible locations.
	ECW-GF-DP	An optional remote display panel (ECW-GF-DP) can be added to provide ground-fault or alarm indication in applications where the controller is mounted in inaccessible locations.
	PD Pro	Automatic snow and ice melting controller for pavement, sidewalks, loading docks, roofs, gutters and downspouts in commercial and residential environments. The PD Pro interfaces with up to two sensors, (any combination of Snow Owl, GIT-1 or SIT-6E) to meet site requirements. The PD Pro is housed in an environmentally-sheltered Type 4X enclosure and weighs only 3 pounds.
	GF Pro	Automatic snow and ice melting controller for pavement, sidewalks, loading docks, roofs, gutters and downspouts in commercial and residential environments. The GF Pro interfaces with up to two sensors, (any combination of Snow Owl, GIT-1 or SIT-6E) to meet site requirements. The GF Pro is housed in an environmentally-sheltered Type 4X enclosure and weighs only 3 pounds. Features a built-in 30 mA, self-testing Ground-Fault Equipment Protection (GFEP) capability, digitally filtered to minimize false tripping. A ground-fault alarm must be manually reset using the Test/Reset switch before heater operation can continue.

Table 10 Control Systems



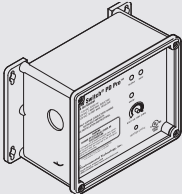
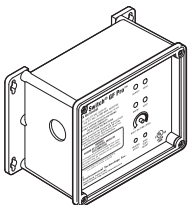

	Catalog number	Description
Automatic Snow Melting Controllers		
	APS-3C	Automatic snow melting controller housed in a Type 3R enclosure provides effective, economical automatic control of all snow melting applications. Features include: 120 V or 208–240 V models, 24-A DPDT output relay and an adjustable hold-on timer. Enclosure dimensions: 11-1/2 in x 9-1/8 in x 6-9/16 in (292 mm x 232 mm x 167 mm)
	APS-4C	Automatic snow melting controller housed in a Type 3R enclosure provides effective, economical automatic control of all snow melting applications. The APS-4C can operate with any number of SC-40C satellite contactors for larger loads. Features include: 277 V single-phase or 208–240, 277/480, and 600 V three-phase models, built-in 3-pole contactor, integral 30 mA ground-fault circuit interrupter and an adjustable hold-on timer. Enclosure dimensions: 11-1/2 in x 9-1/8 in x 6-9/16 in (292 mm x 232 mm x 167 mm)
	SC-40C	Satellite contactor power control peripheral for an APS-4C snow melting controller, housed in a Type 3R enclosure. Features include: 277 V single-phase or 208–240, 277/480 and 600 V three-phase models, built-in 3-pole contactor and integral 30 mA ground-fault circuit interrupter. Enclosure dimensions: 11-1/2 in x 9-1/8 in x 6 in (292 mm x 232 mm x 152 mm)
Snow Melting and Gutter De-Icing Sensors and Accessories		
	Snow Owl	Overhead snow sensor that detects precipitation or blowing snow at ambient temperatures below 38°F (3.3°C). For use with either an APS-3C or APS-4C automatic snow melting controller.
	SIT-6E	Pavement-mounted sensor signals for the heating cable to turn on when the pavement temperature falls below 38°F (3.3°C) and precipitation in any form is present. Microcontroller technology effectively eliminates ice bridging while ensuring accurate temperature measurement. For use with either an APS-3C or APS-4C automatic snow melting controller.
	RCU-3	The RCU-3 provides control and status display to the APS-3C controller from a remote location. It has a 2, 4, 6 or 8 hour CYCLE TIME adjustment, independent of APS-3C setting.
	RCU-4	The RCU-4 provides control and status display to the APS-4C controller and SC-40C Satellite Contactor from a remote location. It has a 2, 4, 6 or 8 hour CYCLE TIME adjustment, independent of the APS-4C or SC-40C setting.

Table 10 Control Systems

	Catalog number	Description
Electronic Controllers		
	ACS-UIT3 ACS-PCM2-5	The ACS-30 Advanced Commercial Control System is a multipoint electronic control and monitoring system for heat-tracing used in various commercial applications such as pipe freeze protection, roof and gutter de-icing, surface snow melting, hot water temperature maintenance and floor heating. The ACS-30 system can control up to 260 circuits with multiple networked ACS-PCM2-5 panels, with a single ACS-UIT3 user interface terminal. The ACS-PCM2-5 panel can directly control up to 5 individual heat-tracing circuits using electromechanical relays rated at 30 A up to 277 V.
	ProtoNode-RER-1.5K ProtoNode-RER-10K	ProtoNode is an external, high performance multi-protocol gateway for customers needing protocol translation between building management systems (BMS) using BACnet® or Metasys® N2 and the C910-485, ACS-30 controller. ProtoNode-RER-1.5K (Part No 2000004256) is for C910-485 or ACS-30 systems with up to 5 PCM panels. ProtoNode-RER-10K (Part No 2000004257) is for ACS-30 systems with up to 34 PCM panels.
	RTD-200 RTD10CS RTD50CS	Stainless steel jacketed three-wire RTD (Resistance Temperature Detector) used with C910-485 and ACS-30 controllers. RTD-200: 3-in (76 mm) temperature sensor with a 6-ft (1.8 m) lead wire and 1/2-in NPT bushing RTD10CS: temperature sensor with a 10-ft (3 m) flexible armor, 18-in (457 mm) lead wire and 1/2-inch NPT bushing RTD50CS: temperature sensor with a 50-ft (15 m) flexible armor, 18-in (457 mm) lead wire and 1/2-in NPT bushing

Power Distribution

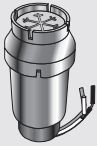
Single Circuit Control

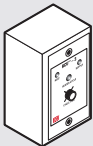
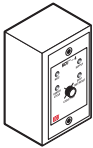
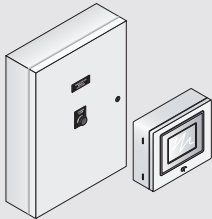
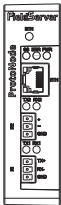
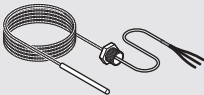
Heating cable circuits that do not exceed the current rating of the selected temperature control can be switched directly (see Fig. 9).

Group Control

If the current draw exceeds the switch rating, or if the controller will activate more than one circuit, or group control, an external contactor must be used (see Fig. 9).

Large systems with many circuits should use an SMPG power distribution panel. The SMPG is a dedicated power-distribution, control, ground-fault protection, monitoring, and alarm panel for surface snow melting and anti-icing applications. This enclosure contains an assembled circuit-breaker panelboard. Panels are equipped with ground-fault circuit breakers with or without alarm contacts. The group control package allows the system to operate automatically in conjunction with an ambient-sensing thermostat, individual electronic, or duty cycle controller.

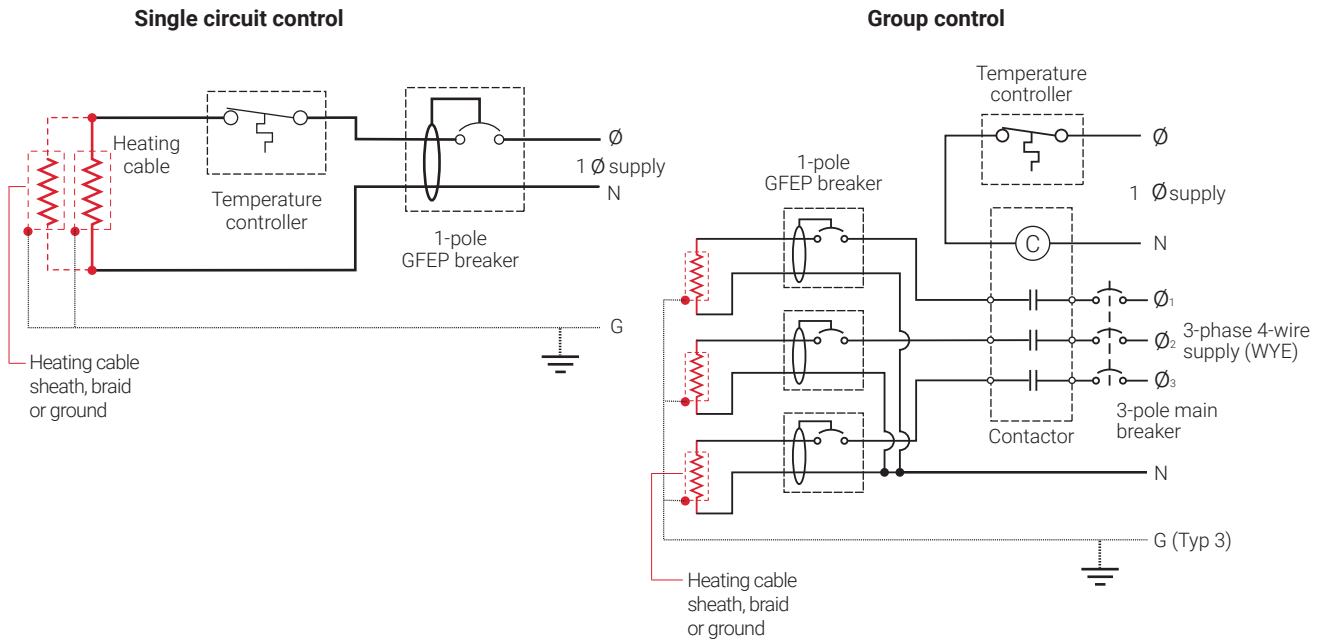

Fig. 9 Single circuit and group control

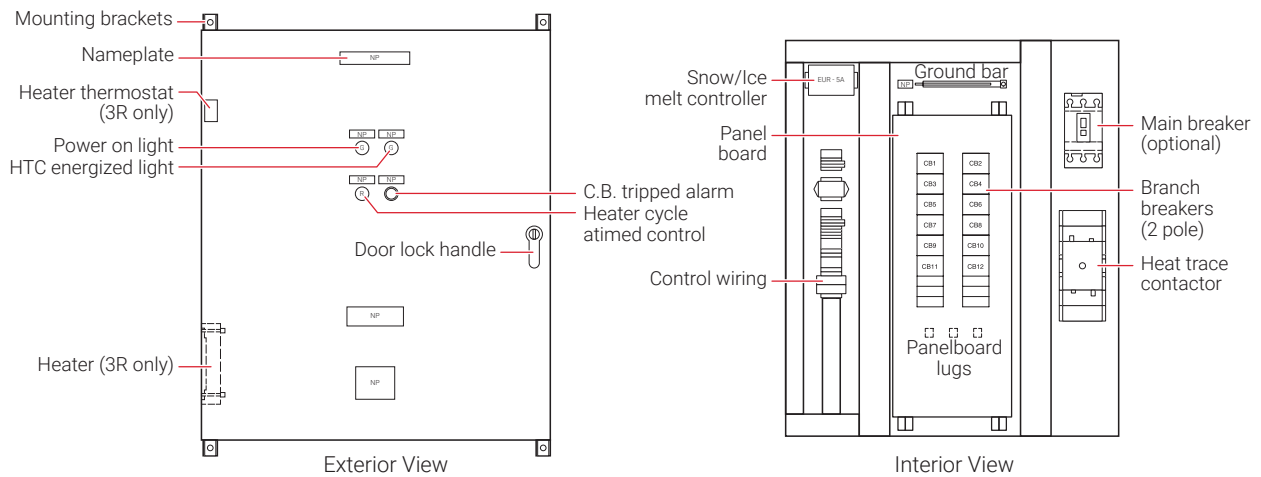

Fig. 10 SMPG1 power distribution panel

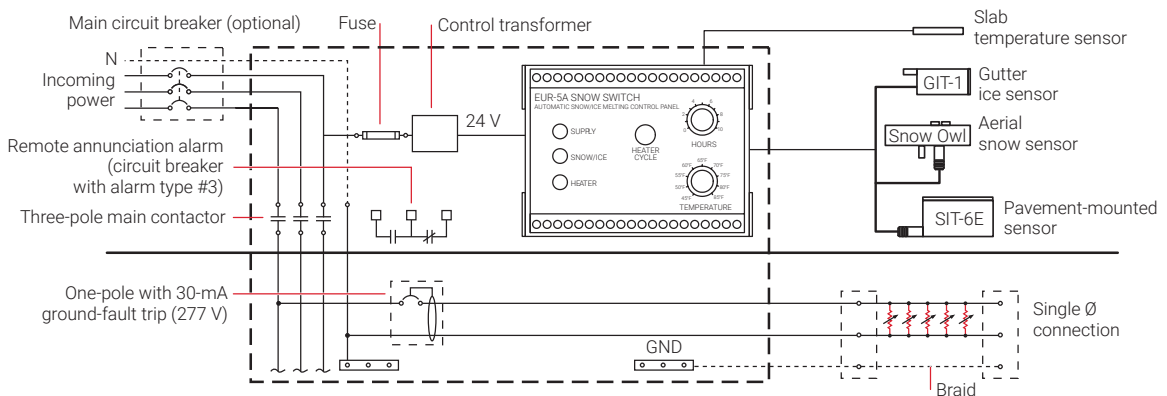
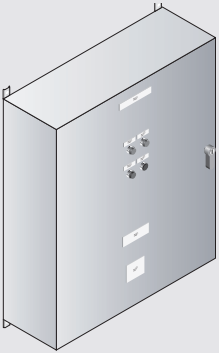

Fig. 11 Typical wiring diagram of group control with SMPG1

Table 11 Power Distribution

	Catalog number	Description
Power Distribution and Control Panels		
	SMPG1	<p>Single-phase power distribution panel that includes ground-fault protection, monitoring, and control for snow melting systems. Single-phase voltages include 208 and 277 V.</p> <p>If standard configurations do not meet your needs, custom SMPG panels are available and processed under the catalog number SMPG-GENERAL, part number P000000763. Please contact your nVent representative for a custom SMPG panel quotation.</p>

Example: Surface Snow Melting System

This system has 16 circuits and will require a specially designed control panel. As many as eight SIT-6E sensors can be used in this configuration. The amount depends upon designer preference.

Example: Anti-Icing System

This system has 18 circuits and will require a specially designed control panel. As many as eight SIT-6E sensors can be used in this configuration. The amount depends upon designer preference.

Surface Snow Melting & Anti-Icing
1. Determine design conditions
2. Select the heating cable
3. Determine the required watt density
4. Determine heating cable spacing
5. Determine the total area to be protected
6. Determine heating cable length
7. Determine the electrical parameters
8. Select the connection kits and accessories
9. Select the control system and power distribution
10. Complete the Bill of Materials

Step 10 Complete the Bill of Materials

If you used the Design Worksheet to document all your design parameters, you should have all the details you need to complete the Bill of Materials.

ELECTROMELT SYSTEM SURFACE SNOW MELTING AND ANTI-ICING DESIGN WORKSHEET

Step 1 Determine design conditions

Application	Size and layout	Supply voltage	Phase	Control method
<input type="checkbox"/> Surface snow melting Geographical location: _____ _____	Slab surface (ft/m) _____ Ramp surface (ft/m) _____ Stairs	<input type="checkbox"/> 208 V <input type="checkbox"/> 240 V <input type="checkbox"/> 277 V	<input type="checkbox"/> Single-phase	<input type="checkbox"/> Manual on/off control <input type="checkbox"/> Slab-sensing thermostat <input type="checkbox"/> Automatic snow melting controller
<input type="checkbox"/> Anti-icing Minimum ambient temperature: _____ _____ Average wind speed during freezing periods (mph/kmph): _____ _____	Number of stairs _____ Width of stair (ft/m) _____ Riser height (in/cm) _____ Depth of stair (in/cm) _____ Landing dimensions (ft/m) _____			
Paving material <input type="checkbox"/> Concrete pavement <input type="checkbox"/> In concrete under paving stones	Wheel tracks Track length (ft/m) _____			

Example:

<input checked="" type="checkbox"/> Surface snow melting <input checked="" type="checkbox"/> Buffalo, NY <input checked="" type="checkbox"/> Concrete slab	Slab surface: 80 ft x 50 ft Stairs Number of stairs 10 Width of stair 5 ft Riser height 6 in Depth of stair 12 in	<input checked="" type="checkbox"/> 277 V	<input checked="" type="checkbox"/> Single-phase	<input checked="" type="checkbox"/> Automatic snow melting controller
---	---	--	---	--

Step 2 Select the heating cable

See Table 1
 EM2-XR

Example:

EM2-XR

Step 3 Determine the required watt density

Surface snow melting
 See Table 2

Anti-icing
 See Table 3 and Table 4

Geographical location: _____ Minimum ambient temperature (°F/°C): _____
 Required watt density (W/ft²)(W/m²): _____ Average wind speed during freezing periods (mph/kmph): _____
 Required watt density (W/ft²)(W/m²): _____

Example:

Geographical location: **Buffalo, NY**
 Required watt density: **40 W/ft²**

Step 4 Determine heating cable spacing

See Table 5

Surfaces

$$\left(\frac{\text{Power output (W/ft)} \times 12 \text{ in/ft}}{\text{Watt density (W/ft}^2\text{)}} \right) \longrightarrow = \text{Heating cable spacing (in)}$$

Note: Round result to the nearest whole number of inches or centimeters.

Stairs

Calculate the heating cable needed for stairs and landing

Determine the number of cable runs needed:

Depth of stair: <10.5 in (27 cm): 2 cable runs

Depth of stair: 10.5–12 in (27–30 cm): 2 cable runs

Cable runs needed: _____

Concrete stair depth (in/cm): _____ Number of cable runs: _____ Spacing: _____

Example:

Surfaces

$$\left(\frac{34 \text{ W/ft} \times 12 \text{ in/ft}}{40 \text{ W/ft}^2} \right) \longrightarrow = 10 \text{ in}$$

Heating cable spacing (in/cm)

Stairs

Note: Round result to the nearest whole number of inches or centimeters.

Calculate the heating cable needed for stairs and landing

Determine the number of cable runs needed:

Depth of stair: <10.5 in (27 cm): 2 cable runs

Depth of stair: 10.5–12 in (27–30 cm): 2 cable runs

Cable runs needed: **2**

Concrete stair depth (in/cm): **12 in** Number of cable runs: **2** Spacing: **Equally spaced across the width of the stair with one run 2 in from the front edge**

Step 5 Determine the total area to be protected

Surfaces

$$\text{Length (ft/m)} \times \text{Width (ft/m)} \longrightarrow = \text{Surface area to be protected (ft}^2\text{/m}^2\text{)}$$

Example:

$$80 \text{ ft} \times 50 \text{ ft} \longrightarrow = 4000 \text{ ft}^2$$

Surface area to be protected (ft)

Step 6 Determine the heating cable length

Surfaces

$$\frac{\text{Total concrete slab area (ft}^2\text{/m}^2)}{\text{Heating cable spacing (in/cm)}} \times 12 \text{ in} \rightarrow = \text{Heating cable length for surface (ft/m)}$$

Calculate the heating cable for stairs and landing

$$\text{No. of stairs} \times \left[\left(\frac{\text{No. of runs per stair}}{\text{Width of stair (ft/m)}} \right) + \left(2 \times \frac{\text{Riser height (ft/m)}}{\text{Riser height (ft/m)}} \right) \right] = \text{Heating cable length for stairs (ft/m)}$$

Note: Additional heating cable for connection kits and end terminations is calculated in Step 8.

Calculate heating cable needed for wheel tracks

$$\text{Length (ft/m)} \times 2 \times 4 \text{ runs} \rightarrow = \text{Wheel track to be protected (ft/m)}$$

Total heating cable length required (ft/m)

Example:

Surfaces

$$\frac{4000 \text{ ft}^2}{\text{Heating cable spacing}} \times 12 \text{ in} / 10 \text{ in} = \frac{4800}{\text{Heating cable length for surface}}$$

Calculate the heating cable for stairs and landing

$$\frac{10}{\text{No. of stairs}} \times \left[\left(\frac{2}{\text{No. of runs per stair}} \times \frac{5 \text{ ft}}{\text{Width of stair}} \right) + \left(2 \times \frac{0.5 \text{ ft}}{\text{Riser height}} \right) \right] = \frac{110 \text{ ft}}{\text{Heating cable length for stairs}}$$

Note: Additional heating cable for connection kits and end terminations is calculated in Step 8.

4910 ft
Total heating cable length required

Step 7 Determine the electrical parameters

See Table 7 and Table 8

Determine number of circuits

$$\frac{\text{Heating cable length required for surface (ft/m)}}{\text{Maximum heating cable circuit length (ft/m)}} = \text{Number of circuits}$$

Determine total transformer load

Calculate circuit breaker load (CBL)

$$\left(\frac{\text{Circuit breaker rating (Amps)}}{\text{Supply voltage}} \times 0.8 \right) / 1000 = \text{Circuit breaker load (kW)}$$

Calculate the total transformer load as follows:

If the CBL is equal on all circuits, calculate the transformer load as:

$$\text{Circuit breaker load (kW)} \times \text{Number of breakers} = \text{Total transformer load (kW)}$$

If the CBL is NOT equal on all circuits, calculate the transformer load as:

$$\text{CBL}_1 + \text{CBL}_2 + \text{CBL}_3 \dots + \text{CBL}_N = \text{Total transformer load (kW)}$$

Example:

Determine number of circuits: Surfaces

$$\frac{4800 \text{ ft}}{325 \text{ ft}} = 14.8 \text{ rounded to } 15$$

Number of circuits

Determine number of circuits: Stair

$$\frac{110 \text{ ft}}{325 \text{ ft}} = 0.3 \text{ rounded to } 1$$

Number of circuits

Determine transformer load

$$\left(\frac{50 \text{ A}}{\text{Supply voltage}} \times 0.8 \right) / 1000 = 11.1 \text{ kW}$$

Circuit breaker load (kW)

$$11.1 \text{ kW} \times 16 = 177.6 \text{ kW rounded to } 178$$

Total transformer load (kW)

Step 8 Select the connection kit and accessories

See Table 9

Connection kits	Description	Quantity	Heating cable allowance
<input type="checkbox"/> EMK-XC	Power connection, end seal kit	_____	_____
<input type="checkbox"/> EMK-XS	Splice kit	_____	_____

Accessories	Description	Quantity	
<input type="checkbox"/> EMK-XJR	Jacket repair kit	_____	
<input type="checkbox"/> EMK-CT	Nylon cable ties	_____	
<input type="checkbox"/> EMK-XT	Crimping tool	_____	
<input type="checkbox"/> SMCS	Snow melt caution sign	_____	
<input type="checkbox"/> EMK-XEJ	Expansion joint kit	_____	_____
<input type="checkbox"/> EMK-JB	Junction box	_____	_____
<input type="checkbox"/> EMK-XCJ	Crack control joint kit	_____	_____

Total heating cable allowance for connection kits

$$\text{Number circuits for concrete slab} + \text{Circuit(s) for stairs} + \text{Circuit(s) for expansion joints} = \text{Total no. of circuits} = \text{Total no. of power connection kits}$$

$$\text{Cable allowance per circuit connection (ft/m)} \times \text{Total number of circuits} = \text{Total heating cable allowance per power connection (ft/m)}$$

Example:

$$15 + 1 + \text{Circuit(s) for expansion joints} = 16 = \text{Total no. of power connection kits}$$

$$1.3 \times 16 = 21 = \text{Total heating cable allowance per power connection}$$

Step 9 Select the control system and power distribution

Control Systems

See Table 10.

Thermostats, controllers and accessories

	Description	Quantity
<input type="checkbox"/> ECW-GF	Electronic thermostat with 25-ft sensor	_____
<input type="checkbox"/> ECW-GF-DP	Remote display panel for ECW-GF	_____
<input type="checkbox"/> PD Pro	Automatic snow and ice melting controller	_____
<input type="checkbox"/> GF-Pro	Automatic snow and ice melting controller	_____
<input type="checkbox"/> APS-3C	Automatic snow and ice melting controller	_____
<input type="checkbox"/> APS-4C	Automatic snow and ice melting controller	_____
<input type="checkbox"/> SC-40C	Satellite contactor	_____
<input type="checkbox"/> Snow Owl	Aerial snow sensor	_____
<input type="checkbox"/> SIT-6E	Pavement-mounted sensor	_____
<input type="checkbox"/> RCU-3	Remote control unit for APS-3C	_____
<input type="checkbox"/> RCU-4	Remote control unit for APS-4C	_____
<input type="checkbox"/> ACS-UIT3	ACS-30 user interface terminal	_____
<input type="checkbox"/> ACS-PCM2-5	ACS-30 power control panel	_____
<input type="checkbox"/> ProtoNode-RER	Multi-protocol gateway	_____
<input type="checkbox"/> RTD3CS	Resistance temperature device for ACS-30	_____
<input type="checkbox"/> RTD10CS	Resistance temperature device for ACS-30	_____
<input type="checkbox"/> RTD-200	Resistance temperature device for ACS-30	_____
<input type="checkbox"/> RTD50CS	Resistance temperature device for ACS-30	_____

Power Distribution

See Table 11.

Power distribution and control panels

	Description	Quantity
<input type="checkbox"/> SMPG1	Single-phase power distribution panel	_____

Step 10 Complete the Bill of Materials

Use the information recorded in this worksheet to complete the Bill of Materials.

Surface Snow Melting System Estimate Form

Email completed form to your nVent Sales Rep for a complete Bill of Materials and quote!

CHECK OUT SNOCALC, OUR ONLINE SURFACE SNOW MELTING DESIGN TOOL
 at <https://www.nVent.com/RAYCHEM/resources/design-tools/tracecalc-pro-buildings>

1. Building Type:	<input type="checkbox"/> House	<input type="checkbox"/> Small shop / strip mall	<input type="checkbox"/> High-rise residential / multi-use bldg.	<input type="checkbox"/> Commercial building
2. Project City, State:				
3. Area Name:				
4. Voltage:	<input type="checkbox"/> 120 V <input type="checkbox"/> 208 V <input type="checkbox"/> 240 V <input type="checkbox"/> 277 V	<input type="checkbox"/> 120 V <input type="checkbox"/> 208 V <input type="checkbox"/> 240 V <input type="checkbox"/> 277 V	<input type="checkbox"/> 120 V <input type="checkbox"/> 208 V <input type="checkbox"/> 240 V <input type="checkbox"/> 277 V	<input type="checkbox"/> 120 V <input type="checkbox"/> 208 V <input type="checkbox"/> 240 V <input type="checkbox"/> 277 V
	<input type="checkbox"/> 347 V <input type="checkbox"/> 480 V <input type="checkbox"/> 600 V	<input type="checkbox"/> 347 V <input type="checkbox"/> 480 V <input type="checkbox"/> 600 V	<input type="checkbox"/> 347 V <input type="checkbox"/> 480 V <input type="checkbox"/> 600 V	<input type="checkbox"/> 347 V <input type="checkbox"/> 480 V <input type="checkbox"/> 600 V
5. Voltage Configuration:	<input type="checkbox"/> 1 Phase <input type="checkbox"/> 3 Phase	<input type="checkbox"/> 1 Phase <input type="checkbox"/> 3 Phase	<input type="checkbox"/> 1 Phase <input type="checkbox"/> 3 Phase	<input type="checkbox"/> 1 Phase <input type="checkbox"/> 3 Phase
6. Breaker Size:	<input type="checkbox"/> 20 A <input type="checkbox"/> 30 A <input type="checkbox"/> 40 A <input type="checkbox"/> 50 A	<input type="checkbox"/> 20 A <input type="checkbox"/> 30 A <input type="checkbox"/> 40 A <input type="checkbox"/> 50 A	<input type="checkbox"/> 20 A <input type="checkbox"/> 30 A <input type="checkbox"/> 40 A <input type="checkbox"/> 50 A	<input type="checkbox"/> 20 A <input type="checkbox"/> 30 A <input type="checkbox"/> 40 A <input type="checkbox"/> 50 A
	<input type="checkbox"/> 60 A <input type="checkbox"/> 80 A <input type="checkbox"/> 100 A	<input type="checkbox"/> 60 A <input type="checkbox"/> 80 A <input type="checkbox"/> 100 A	<input type="checkbox"/> 60 A <input type="checkbox"/> 80 A <input type="checkbox"/> 100 A	<input type="checkbox"/> 60 A <input type="checkbox"/> 80 A <input type="checkbox"/> 100 A
7. Area Type:	<input type="checkbox"/> Concrete	<input type="checkbox"/> Concrete	<input type="checkbox"/> Concrete	<input type="checkbox"/> Concrete
	<input type="checkbox"/> Asphalt	<input type="checkbox"/> Asphalt	<input type="checkbox"/> Asphalt	<input type="checkbox"/> Asphalt
	<input type="checkbox"/> Pavers	<input type="checkbox"/> Pavers	<input type="checkbox"/> Pavers	<input type="checkbox"/> Pavers
	<input type="checkbox"/> Stairs (on grade)	<input type="checkbox"/> Stairs (on grade)	<input type="checkbox"/> Stairs (on grade)	<input type="checkbox"/> Stairs (on grade)
	<input type="checkbox"/> Stairs (elevated)	<input type="checkbox"/> Stairs (elevated)	<input type="checkbox"/> Stairs (elevated)	<input type="checkbox"/> Stairs (elevated)
	<input type="checkbox"/> Wheel Tracks (concrete)	<input type="checkbox"/> Wheel Tracks (concrete)	<input type="checkbox"/> Wheel Tracks (concrete)	<input type="checkbox"/> Wheel Tracks (concrete)
	<input type="checkbox"/> Wheel Tracks (asphalt)	<input type="checkbox"/> Wheel Tracks (asphalt)	<input type="checkbox"/> Wheel Tracks (asphalt)	<input type="checkbox"/> Wheel Tracks (asphalt)
8. Number of Steps:				
9. Stair Width:	_____ ft	_____ ft	_____ ft	_____ ft
10. Stair Depth:	_____ in	_____ in	_____ in	_____ in
11. Riser Height:	_____ in	_____ in	_____ in	_____ in
12. Landing Area:	_____ sq ft	_____ sq ft	_____ sq ft	_____ sq ft
13. Total Area (not including landing):	_____ sq ft	_____ sq ft	_____ sq ft	_____ sq ft
14. Number of Expansion Joints:				
15. Feet from Junction Box to Slab:	_____ ft	_____ ft	_____ ft	_____ ft
16. Junction Box Height Above Grade:	_____ ft	_____ ft	_____ ft	_____ ft
17. If Wheel Track Design, Length of Tracks:	_____ ft	_____ ft	_____ ft	_____ ft
18. Control:	<input type="checkbox"/> Control Only	<input type="checkbox"/> Control Only	<input type="checkbox"/> Control Only	<input type="checkbox"/> Control Only
	<input type="checkbox"/> Control w/ Power Dist	<input type="checkbox"/> Control w/ Power Dist	<input type="checkbox"/> Control w/ Power Dist	<input type="checkbox"/> Control w/ Power Dist
19. Controls Provide GFPD?	<input type="checkbox"/> Yes <input type="checkbox"/> No	<input type="checkbox"/> Yes <input type="checkbox"/> No	<input type="checkbox"/> Yes <input type="checkbox"/> No	<input type="checkbox"/> Yes <input type="checkbox"/> No
20. Notes:	BUSINESS CARD			
21. Customer name:				
Company:				
Phone:				
Email:				
Project name:				



North America

Tel +1.800.545.6258
Fax +1.800.527.5703
thermal.info@nVent.com



Our powerful portfolio of brands:

CADDY ERICO HOFFMAN ILSCO RAYCHEM SCHROFF

©2024 nVent. All nVent marks and logos are owned or licensed by nVent Services GmbH or its affiliates. All other trademarks are the property of their respective owners. nVent reserves the right to change specifications without notice.

RAYCHEM-DG-H53393-EMSnowMelting-EN-2405