

TT1100-OHP-THIN

CONNECT AND PROTECT

Water sensing cable for insulated pipe

PRODUCT OVERVIEW



nVent RAYCHEM TraceTek TT1100-OHP-THIN sensor cable detects water leaks at any point along the cable length. When used in conjunction with nVent RAYCHEM TraceTek monitoring instruments, the cable senses the presence of a water leak, triggers an alarm and pinpoints the location of the leak to within ± 1 meter accuracy.

Targeted design for insulated pipe

TT1100-OHP-THIN sensor cable is designed for use on insulated pipes that require a very small cable diameter. TT1100-OHP-THIN is made with a porous fluoropolymer outer fiber braid surrounding the base nVent RAYCHEM TraceTek TT1100 sensor cable. The fluoropolymer fiber overbraid produces an easy-to-install cable that provides superior flexibility (bend radius). The mechanically strong fluoropolymer outer braid also stands up to the compression forces associated with the use of sheet metal lagging surrounding the pipe insulation.

TT1100-OHP-THIN sensor cable is designed so that once a water leak is located and repaired, the cable will quickly dry and be ready for re-use, in many cases as soon as pipe repairs are made.

Distributed sensing

TT1100-OHP-THIN sensor cable provides distributed leak detection and location along the entire run of cable. Cable can be installed around localized sources of water leakage (e.g. valves, pumps and tanks) as well as along insulated pipe.

Strap directly to the insulation

TT1100-OHP-THIN should be positioned along the bottom of the insulation, held in place with thin tape and then secured by and within the sheet metal lagging. The outer fiber braid on the TT1100-OHP-THIN sensor cable provides extra electrical stand-off insulation and strength for ease of installation in construction environments.

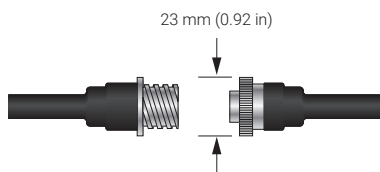
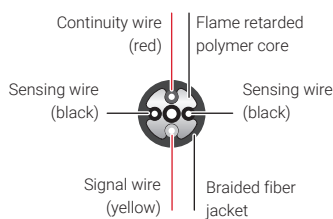
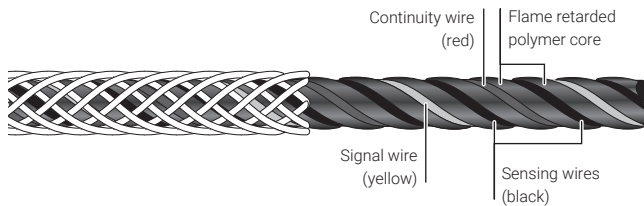

Cable construction

Design flexibility

Individual circuit lengths up to 1000 m can be monitored from a single sensor interface module (SIM). Multiple SIMs can be easily networked to provide extended coverage along pipelines. Alarm and control panels with capacity for up to 127 SIMs are standard. TraceTek supervisor (for Windows PC) is available for stand alone installations, or the SIM units can be directly connected to the facility alarm and control systems.

TT1100-OHP-THIN is available in bulk lengths or pre-terminated in standard lengths. TT1100-OHP-THIN is compatible with all nVent RAYCHEM TraceTek instruments and software.

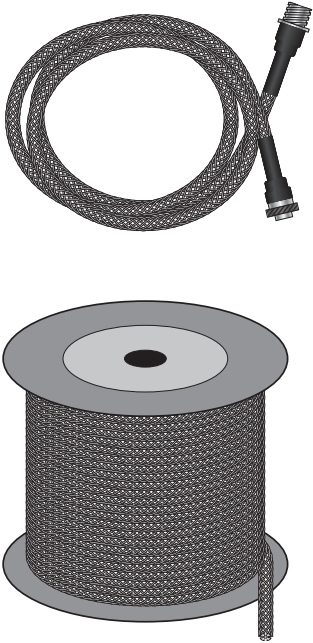

ORDERING INFORMATION

TT1100-OHP modular sensing cable with factory-installed connectors

Catalog number	Part number	Description
TT1100-OHP-THIN-1M-PC	P000001257	3 ft (1 m) sensing cable
TT1100-OHP-THIN-3M-PC	P000001256	10 ft (3 m) sensing cable
TT1100-OHP-THIN-7.5M-PC	P000001255	25 ft (7 m) sensing cable
TT1100-OHP-THIN-15M-PC	P000001254	50 ft (15 m) sensing cable
TT1100-OHP-THIN-30M-PC	P000001253	100 ft (30 m) sensing cable
TT1100-OHP-THIN-50M-PC	P000001252	165 ft (50 m) sensing cable
TT1100-OHP-THIN-100M-PC	P000001251	328 ft (100 m) sensing cable
TT1100-OHP-THIN-XX-PC	P000001258	User definable custom length between 1 and 500 ft

TT1100-OHP bulk sensing cable (connector kits required)

Catalog number	Part number	Description
TT1100-OHP-THIN-SC	P000001250	Bulk sensing cable on reel Minimum length: 350 ft (75 m) Maximum length: 1000 ft (300 m)

Connector kits (not shown)

Catalog number	Part number	Description
TT-1100-OHP-CK-PC-M/F	P000001186	Components for ten mated pairs of connectors

PRODUCT CHARACTERISTICS

Cable core diameter	5.5 mm (0.22 in) nominal
Cable diameter with braid	6.8 mm (0.27 in) nominal
Braided fiber jacket	Color – white
Connector diameter	23 mm (0.92 in) nominal
Signal wires	2 x 26 AWG with fluoropolymer insulation
Sensing wires	2 x 30 AWG with conductive fluoropolymer jacket
Core	Flame retarded polymer
Cable weight	3.7 kg / 100 m nominal (2.5 lb / 100 ft nominal)

TECHNICAL INFORMATION

Crush resistance	>100 kg/cm ² (1400 lb/in ²)
Maximum continuous operating temperature	80°C
Leak location accuracy	+/- 1 m (3.3 ft)
Resettable	Can be reused after cable is allowed to dry
Resistance to humidity	<2 µA leakage per 100 feet @ 90% RH / 20°C

APPROVALS AND CERTIFICATIONS

TT1100-OHP-THIN sensing cables are approved for installation in ordinary and hazardous areas when used in conjunction with approved nVent RAYCHEM TraceTek monitoring equipment and zener safety barriers when appropriate.

All nVent RAYCHEM TraceTek sensing cables are designated as “simple apparatus” and included in the approval certification for nVent RAYCHEM TraceTek monitoring instruments.

Consult the specific data sheets and approval certificates for the nVent RAYCHEM TraceTek TTSIM-128, TTSIM-1, TTSIM-1A, TTSIM-2, TTC-1 and TT-FLASHER-BE for application limitations and specific area approvals and certifications.



General Signaling Equipment
76LJ



The TT1100-OHP-THIN sensing cable is FM approved in the TraceTek Leak Detection System when installed with a TraceTek Alarm and Locator Module to detect and locate water.

North America

Tel +1.800.545.6258
Fax +1.800.527.5703
thermal.info@nVent.com

Europe, Middle East, Africa

Tel +32.16.213.511
Fax +32.16.213.603
thermal.info@nVent.com

Asia Pacific

Tel +86.21.2412.1688
Fax +86.21.5426.3167
cn.thermal.info@nVent.com

Latin America

Tel +1.713.868.4800
Fax +1.713.868.2333
thermal.info@nVent.com



Our powerful portfolio of brands:

CADDY ERICO HOFFMAN RAYCHEM SCHROFF TRACER